

## 43GB 行星齿轮箱 Planetary Gearbox



### 通用技术条件 General Technical Requirements

齿圈材料 Ring material	金属 Metal/金属粉末 Powder metal
输出轴轴承型式 Bearing at output	滚珠轴承 Ball bearings
最大允许径向负载 Max. Radial load	≤50N
最大允许轴向负载 Max. shaft axial load	≤30N
径向间隙 Radial play of shaft	≤0.07mm
轴向间隙 Axial play of shaft	≤0.5mm
输出轴最大承受压入力 Shaft press fit force,max.	≤120N

### 齿轮箱减速比和外形尺寸 Reduction ratio and external dimensions

#### 43GB行星齿轮箱减速比

传动级数 Stage	减速比 Reduction ratio					
	一级 Stage1	3.6:1	4.25:1	5.3:1		
二级 Stage2	13:1	15:1	18:1	23:1		
三级 Stage3	47:1	55:1	68:1	76:1	95:1	151:1
四级 Stage4	167:1	247:1	326:1	406:1	632:1	789:1

#### 43GB行星齿轮箱额定扭矩

传动级数 Transmission Stage	机身长度 Length	额定扭矩 Rated torque	瞬间承受扭矩 Instant torque	传动效率 Efficiency
一级 Stage1	37.6mm	0.5NM	1.3NM	90%
二级 Stage2	49.5mm	2.0NM	5NM	81%
三级 Stage3	60mm	4.0NM	10NM	73%
四级 Stage4	70.5mm	5NM	13NM	66%

#### 43GB行星齿轮箱外形尺寸

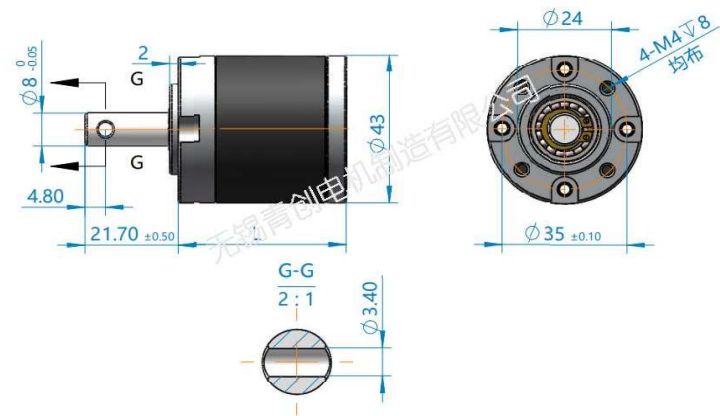

※ 以上尺寸仅供参考! The above size is for reference only!

### 可定制项目 Customizable Projects

项目 Projects	是否可定制
安装方式 Way to install	是 Yes
轴 Shaft	是 Yes
齿轮材料 Gear material	是 Yes
耐高温等级 Heat resistance	是 Yes
防护等级 Level of protection	是 Yes



### 结构示意图 Structure diagram

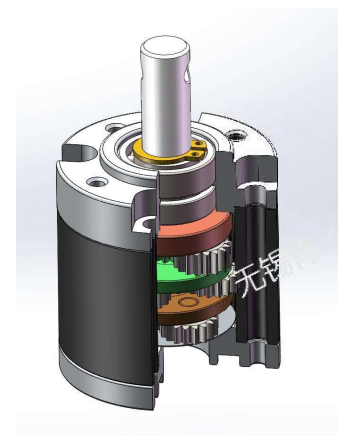

工作温度 Operating temperature	-10°C ~ +80°C
润滑方式 Lubrication type	终身润滑 Lifetime lubrication
安装方式 Mounting typen	任意安装 Any
推荐输入转速 Recommnd input speed	≤3000RPM
输入输出转向 Input and output direction	相同 Same direction

