

### 按钮开关系列 及指示灯

#### 技术参数 Technical parameters

灯光电压 LED Voltage	工作电压(最小到最大) Operating Voltage (Min to Max)	操作电流(典型的所有类型) Operating Current (Typical All Typs)
2VDC(无电阻 No Resistor)	1.8-2.5VDC	20mA
12VDC	10.8-13.2VDC	20mA
24VDC	21.6-26.4VDC	20mA
28VDC	25.2-30.8VDC	20mA
110VAC	99-121VDC	6mA
230VAC	207-253VDC	3mA

灯光颜色 Intensity(Typical) at Iop Standard	发光强度Luminous intensity (所有电压all voltages)	发光强度Luminous intensity (所有电压all voltages)
红色 Red	7,500mcd	2000mcd
绿色 Green	4,100mcd	250mcd
黄色 Yellow	2,500mcd	350mcd
蓝色 Blue	1,300mcd	300mcd
白色 White	1,900mcd	200mcd

发光强度会降低工作电流。  
Luminous intensity will reduce lower operating current.

最大电压 / Max Voltage	5V
观察角度 / Viewing Angle	100° (辅助模式auxiliary pattern)
平均寿命 / Life Expectancy	50, 000 hours
工作温度范围/ Operating Temperature Range	-40~+85℃

#### LED 灯珠参数 LED Ratings

灯珠类型Lamp Type	双向LED灯珠(交直流通用) LED lamp(AC/DC)
额定电压Rated Voltage	AC/DC6V AC/DC12V AC/DC6V V AC/DC12V
额定电流Rated Current	约15mA About 15mA
发光颜色LED Color	R G Y B W
寿命Life	40000小时(参考值) 40000 hours(Reference)

#### 灯珠等效电路 Lamp Circuit diagram



采用交直流通用的LED灯珠，接线端子无正负极区分；灯珠内置保护电阻，不需外接。  
Using AC/DC LED lamp, the terminals have no difference of anode and cathode; Using inner resistance, do not need connect outer resistance. MP16 haven't inner resistance, need connect outer resistance.

#### 特性 / Features

- 安装直径 / Installation diameter:  
6/8/12/16/19/22/28/30mm
- 防护等级 / Degree of Protection: IP65/IP67/IPK10
- 使用弧面、平面、凹面灯罩，外形美观
- 超薄面板设计
- 采用交直流通用LED灯珠

注：如需单向直流LED灯珠可定做；其他电压规格可按需求定做。  
DC LED and other voltage can be made to order.

# YIEDEA TECHNOLOGY

Lamp Series

## 金属信号灯系列

### 按钮开关系列及指示灯

型号命名 / Select code

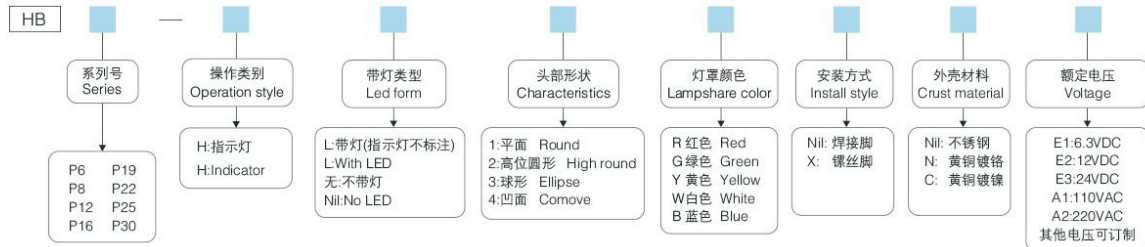

### Ø6 金属信号灯 Metal indicator lamp

名称 / 外观 Product appearance	操作类别 Operation	带灯形式 Led form	产品型号 Model	灯罩颜色 Top Color	外形尺寸 Overall dimension
平面指示灯 Comove indicator 	指示灯 Indicator	带灯 With LED	P6-H1 ●	<ul style="list-style-type: none"> <li><span style="color: red;">■</span> 红色 Red</li> <li><span style="color: green;">■</span> 绿色 Green</li> <li><span style="color: yellow;">■</span> 黄色 Yellow</li> <li><span style="color: white;">■</span> 白色 White</li> <li><span style="color: blue;">■</span> 蓝色 Blue</li> <li><span style="color: orange;">■</span> 橙色 Orange</li> </ul>	

### 安装尺寸及接线图 / Installation size & Contacts circuit

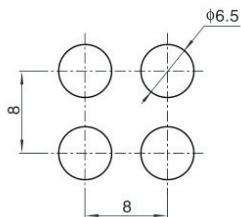





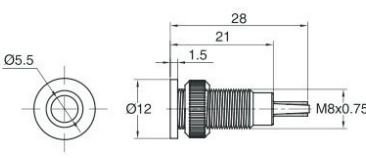

# YIEDEA TECHNOLOGY

Lamp Series

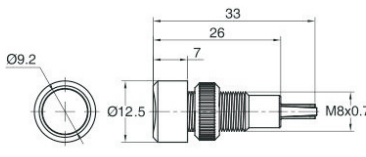
## 金属信号灯系列

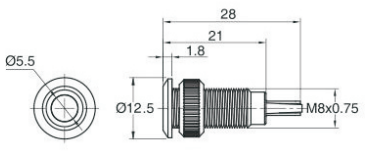
### Ø8 金属信号灯 Metal indicator lamp

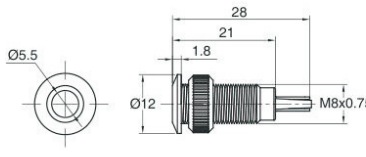
名称 / 外观 Product appearance	操作类别 Operation	带灯形式 Led form	产品型号 Model	灯罩颜色 Top Color	外形尺寸 Overall dimension
平面指示灯 Flat indicator 	指示灯 Indicator	带灯 With LED	P8-H1 ●		
高位圆形指示灯 High round indicator 	指示灯 Indicator	带灯 With LED	P8-H2 ●		
弧面指示灯 Curved indicator 	指示灯 Indicator	带灯 With LED	P8-H3 ●		
凹面指示灯 Concave indicator 	指示灯 Indicator	带灯 With LED	P8-H4 ●		

- R 红色 Red
- G 绿色 Green
- Y 黄色 Yellow
- W 白色 White
- B 蓝色 Blue
- O 橙色 Orange

### 安装尺寸及接线图 / Installation size & Contacts circuit

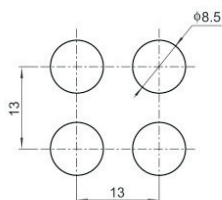





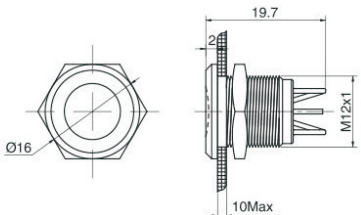

# YIEDEA TECHNOLOGY

Lamp Series

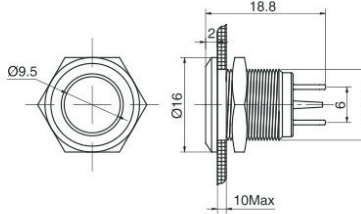
## 金属信号灯系列

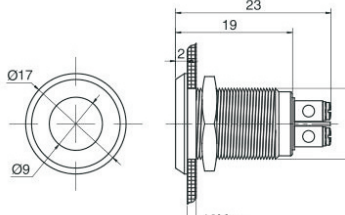
### Ø 12 金属信号灯 Metal indicator lamp

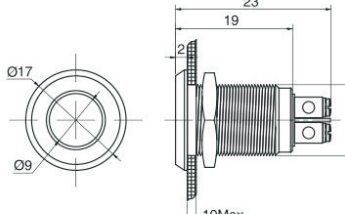
名称 / 外观 Product appearance	操作类别 Operation	安装方式 Install style	产品型号 Model	灯罩颜色 Top Color	外形尺寸 Overall dimension
平面指示灯 Flat indicator  	指示灯 Indicator	焊线型 PCB Type	P12-H1 ●		
凹面指示灯 Concave indicator  	指示灯 Indicator	焊线型 PCB Type	P12-H4 ●		
平面指示灯 Flat indicator  	指示灯 Indicator	螺丝型 Screw Type	P12-H3 ● / X	R 红色 Red G 绿色 Green Y 黄色 Yellow W 白色 White B 蓝色 Blue O 橙色 Orange	
凹面指示灯 Concave indicator  	指示灯 Indicator	螺丝型 Screw Type	P12-H4 ● / X		

### 安装尺寸及接线图 / Installation size & Contacts circuit

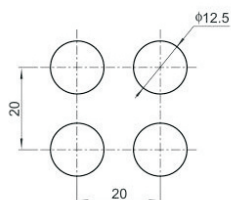





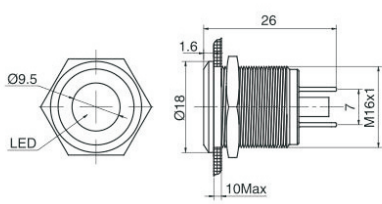

# YIEDEA TECHNOLOGY

Lamp Series

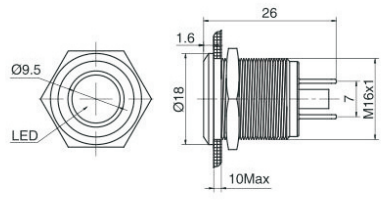
## 金属信号灯系列

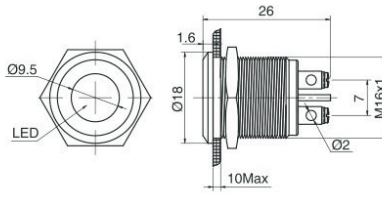
### Ø 16 金属信号灯 Metal indicator lamp

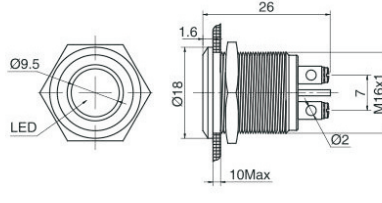
名称 / 外观 Product appearance	操作类别 Operation	安装方式 Install style	产品型号 Model	灯罩颜色 Top Color	外形尺寸 Overall dimension
平面指示灯 Flat indicator  	指示灯 Indicator	焊线型 PCB Type	P16-H1 ●		
凹面指示灯 Concave indicator  	指示灯 Indicator	焊线型 PCB Type	P16-H4 ●		
平面指示灯 Flat indicator  	指示灯 Indicator	螺丝型 Screw Type	P16-H3 ● /X	R 红色 Red G 绿色 Green Y 黄色 Yellow W 白色 White B 蓝色 Blue O 橙色 Orange	
凹面指示灯 Concave indicator  	指示灯 Indicator	螺丝型 Screw Type	P16-H4 ● /X		

### 安装尺寸及接线图 / Installation size & Contacts circuit

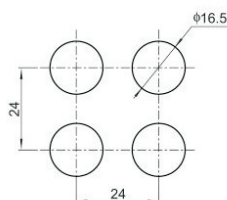





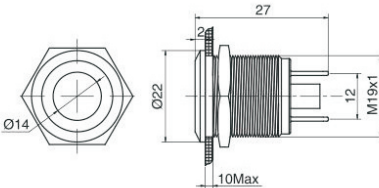

# YIEDEA TECHNOLOGY

Lamp Series

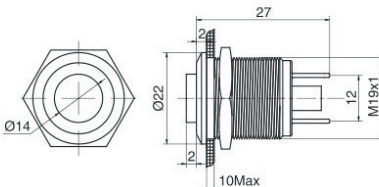
## 金属信号灯系列

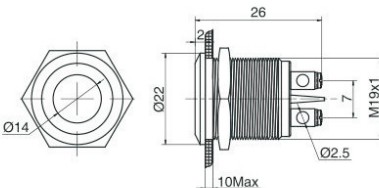
### Ø 19 金属信号灯 Metal indicator lamp

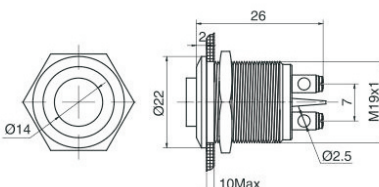
名称 / 外观 Product appearance	操作类别 Operation	安装方式 Install style	产品型号 Model	灯罩颜色 Top Color	外形尺寸 Overall dimension
平面指示灯 Flat indicator  	指示灯 Indicator	焊线型 PCB Type	P19-H1 ●		
高位指示灯 High indicator  	指示灯 Indicator	焊线型 PCB Type	P19-H2 ●		
平面指示灯 Flat indicator  	指示灯 Indicator	螺丝型 Screw Type	P19-H1 ● /X	R 红色 Red G 绿色 Green Y 黄色 Yellow W 白色 White B 蓝色 Blue O 橙色 Orange	
高位指示灯 High indicator  	指示灯 Indicator	螺丝型 Screw Type	P19-H2 ● /X		

### 安装尺寸及接线图 / Installation size & Contacts circuit

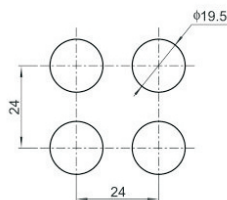





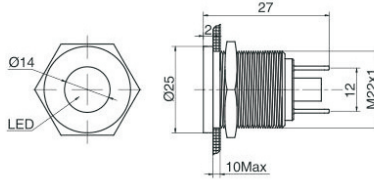

# YIEDEA TECHNOLOGY

Lamp Series

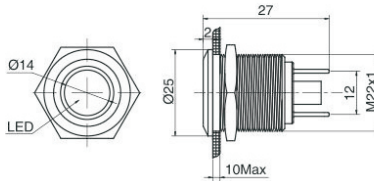
## 金属信号灯系列

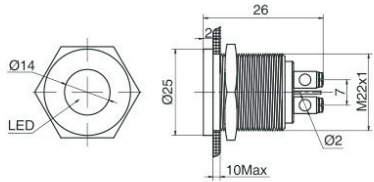
### Ø22 金属信号灯 Metal indicator lamp

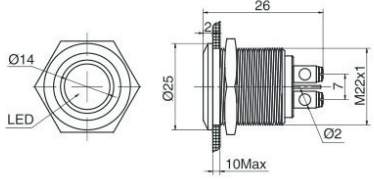
名称 / 外观 Product appearance	操作类别 Operation	安装方式 Install style	产品型号 Model	灯罩颜色 Top Color	外形尺寸 Overall dimension
平面指示灯 Flat indicator  	指示灯 Indicator	焊线型 PCB Type	P22-H1 ●		
凹面指示灯 Concave indicator  	指示灯 Indicator	焊线型 PCB Type	P22-H4 ●		
平面指示灯 Flat indicator  	指示灯 Indicator	螺丝型 Screw Type	P22-H1 ● /X	R 红色 Red G 绿色 Green Y 黄色 Yellow W 白色 White B 蓝色 Blue O 橙色 Orange	
凹面指示灯 Concave indicator  	指示灯 Indicator	螺丝型 Screw Type	P22-H4 ● /X		

### 安装尺寸及接线图 / Installation size & Contacts circuit

