

User's Manual

Triple-IN GmbH
Experts in Laser Distance Measurement

INvention
INnovation
INterfacing



PAC250-90-y-zz+ Laser Scanners

PAC250-90-4-18+

PAC250-90-y-zz+



Content

1	ABOUT THIS DOCUMENT	5
2	SAFETY INSTRUCTIONS	6
2.1	General warnings	6
2.2	Limited warranty.....	7
2.3	General handling instructions	7
3	TRIPLE-IN'S KEM TIME-OF-FLIGHT TECHNOLOGY	8
3.1	Laser Spot Size and Sigma Diagrams	9
4	OPERATING FEATURES	11
4.1	System parts.....	11
4.2	Point of origin and scan area.....	13
5	TRANSPORT, INSTALLATION AND MAINTENANCE	15
5.1	General handling instructions	15
5.2	Packaging and transport	15
5.3	Condensation avoidance	16
5.4	Cleaning.....	16
5.5	Mechanical integration	16
6	CONNECTORS	18
6.1	Phoenix SPEEDCON® quick locking system.....	18
6.2	Data and PoE connector	19
6.3	Multifunction Cable connector	21
7	MICROSOFT WINDOWS SOFTWARE TOOLS	27
7.1	TeraTerm for the RS232 Serial Interface.....	27
7.2	TCP/IP Manager for managing network configurations	28
7.3	Triple-IN PSControlProgram	29
8	SETTING INTO OPERATION	31
8.1	Startup Procedure.....	31
8.2	Serial RS232 Communication	32
8.3	Ethernet connection	35
8.4	Configuration	41
8.5	Taking Scans	41
8.6	Measurement filters	45
8.7	Master echo selection	47
8.8	Using Digital Outputs	48
8.9	Using digital inputs	50
8.10	Controlling the heater	52
8.11	Reading the external Incremental Encoder	52
9	WEB INTERFACE	54
9.1	Sensor information page	54
9.2	User parameters page	55
9.3	Network page.....	56
9.4	Scan page	57

- 9.5 View page 58
- 9.6 Tools page 59
- 9.7 Contacts page 60
- 10 FIRMWARE UPDATE..... 61**
- 10.1 Updating MPU firmware 61
- 10.2 Updating APU firmware 62
- 11 TROUBLESHOOTING..... 64**
- 11.1 LED indicators 64
- 11.2 Self-test messages and System Health status..... 64
- A SYSTEM STATUS BITS..... 69**
- B TECHNICAL SPECIFICATION 70**

Copyright © 2018 Triple-IN GmbH

All rights reserved, including the right to reproduce this book or portions thereof in any form whatsoever. All trademarks, product names and logos are the property of their respective owners.

1 About this document

Triple-IN's PAC250-90-y-zz+ Laser Scanners are multi-layer laser scanners for outdoor automation, industrial applications, security and surveying.

- long range;
- large scan angle;
- small spot size;
- accurate in range and angle;
- fast scan rate;
- robust, IP67;
- real time data through Ethernet.

PAC250-90-y-zz+ Laser Scanners provide rapidly and efficiently accurate and detailed 3D data. PAC250-90-y-zz+ Laser Scanners are suitable for both indoor and outdoor applications, ensuring also goals achievement for existing systems integration. This document describes the PAC250-90-y-zz+ Laser Scanners family. It is related to the:

PS Firmware Version 3.04.05

This User's Manual is part of a set of documents:

Manual	Targeted persons	Content
User's Manual	Technical personnel	Transport, mounting and installation Wiring and maintenance Operating means, system configuration Technical data
Programmer's Manual	Software developers	Data formats Commands and responses
APU Developer's Manual	Software developers	Developer environment setup Specific APU features

If you or your colleagues have any comments on this manual, we would be grateful to hear from you. Please write to:

Triple-IN GmbH
 Poppenbütteler Bogen 64
 D-22399 Hamburg - Germany
 Telefon +49(0)40 50091998
 Mail info@triple-in.de

2 Safety Instructions

2.1 General warnings



Caution

Before using the PAC250-90-y-zz+ Laser Scanners, the user manual must be read, and all the instructions must be carefully observed.

The PAC250-90-y-zz+ Laser Scanners must be installed, configured and serviced only by qualified personnel.

National and international rules and regulations must be applied according to the field of application and usage.

PAC250-90-y-zz+ Laser Scanners cannot be used as safety devices.



Caution



The measurement laser is a laser class 1 product. Emits invisible light (905 nm). Do not look directly into the laser beam!

Red laser marker is a laser class 2 product. Emits visible light (635 to 678 nm). Do not look directly into the laser beam!



Caution



To reduce the risk of electric shock, do not remove the cover. Device contains high voltage components!

Connect and disconnect electrical linkages only under de-energized conditions.



Warning

Do not open the PAC250-90-y-zz+ Laser Scanners.

If opened, the mechanical adjustment will be damaged, and warranty will get void!

2.2 Limited warranty

Triple-IN's General Condition of Sales grants limited warranty for defects in material or workmanship in the PAC250-90-y-zz+ Laser Scanners.



Limited Warranty

The limited warranty does not cover:

- (a) Any problem that is caused by accident, abuse, neglect, shock, electrostatic discharge, degaussing, heat or humidity beyond product specifications, improper installation, operation, maintenance or modification;
- (b) Any use contrary to the instructions in this and other related manuals;
- (c) Lost firmware passwords;
- (d) Malfunctions caused by other equipment;
- (e) Damage resulting during shipment (Claim must be presented and examined by the shipper);
- (f) Damages resulting from modifications or alterations to the product in any way, including any alterations or removal of its identification marks and labels.

2.3 General handling instructions

PAC250-90-y-zz+ Laser Scanners are delicate optical instruments. Such equipment must be handled with special care to protect the sensors from possible damage.



Caution



Don't exert any pressure on the device.
Do not open the device.

3 Triple-IN's KEM Time-of-Flight Technology

The technological basis for the Triple-IN PAC250-90-y-zz+ Laser Scanners is "Time-of-Flight" (ToF): the travel time of light emitted by a laser diode to natural surface. Triple-IN's KEM method ("kontinuierliche Event Messung", "Continuous Event Measurement) improves this well-known technology:

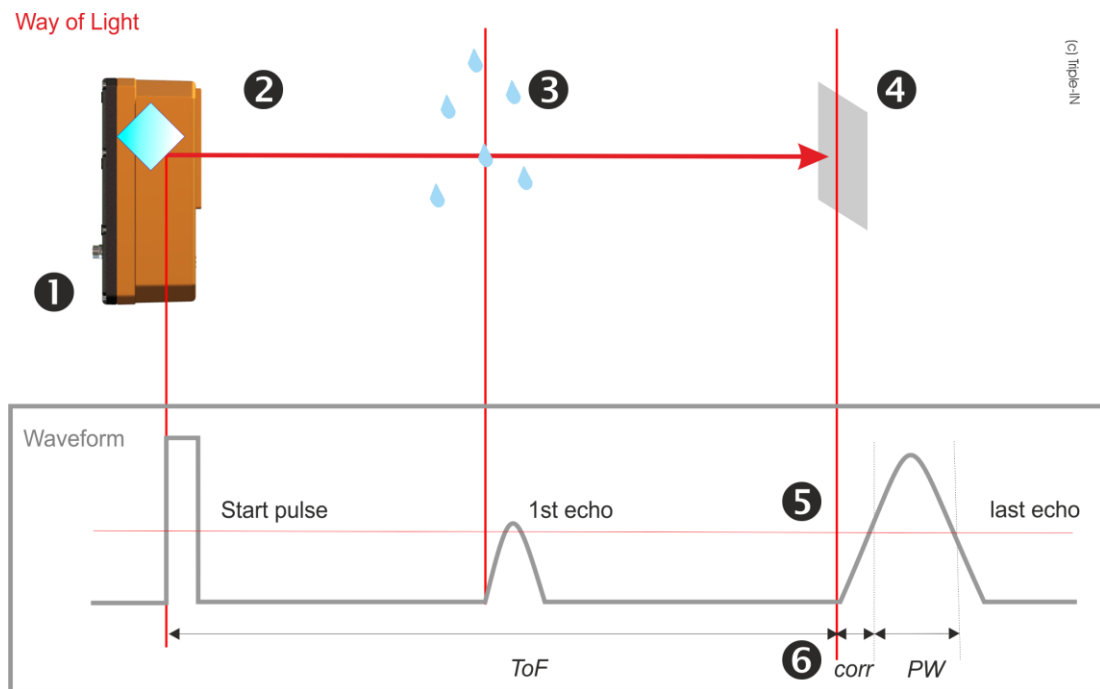

Figure 1: Principle of operation

1. The angle encoder triggers the laser diode in regular angle steps. The laser diode emits an infrared laser beam, defining the reference "Start pulse" which marks the beginning of the time-of-flight measurement.
2. The mirror, which is connected to the angle encoder, reflects the laser beam in certain directions. An even scan area is formed by the rotation of the mirror.
3. The laser beam is reflected by natural surfaces. Several echoes can be the result of window panes, rain drops, snowflakes and similar objects which reflect parts of the laser pulse's energy. This effect is called "multi-echo". PAC250-90-y-zz+ Laser Scanners can record the results of up to 4 echoes for each laser beam.
4. The echo signal varies depending on the surface reflectivity and the distance to the object. The echo signal will be detected as soon as it passes a receiver

threshold. The sensor measures the time-of-flight and the pulse width of the echo signal.

5. The KEM technology applies various corrections to compensate deviations from the echo signal strength.
6. The result is an accurate time-of-flight measurement, independently of the temperature, reflectivity, and target distance.
The distance to the target is calculated by

$$d = \text{ToF} * C / 2 - \text{Corr}$$

Where

d = distance
 ToF = measured time-of-flight
 C = speed of light in ambient atmosphere
 Corr = echo signal corrections

3.1 Laser Spot Size and Sigma Diagrams

The next diagrams are drawn using data collected by a sensor model PAC250-90-4-18+.

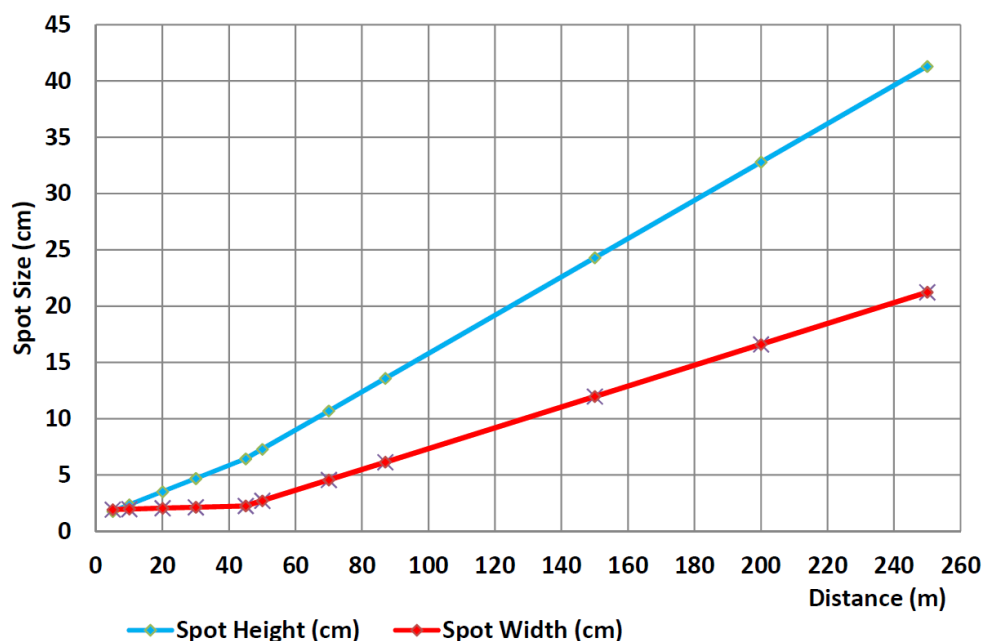

Figure 2: Spot size as function of distance



Figure 3: Sigma as function of distance

4 Operating features

4.1 System parts

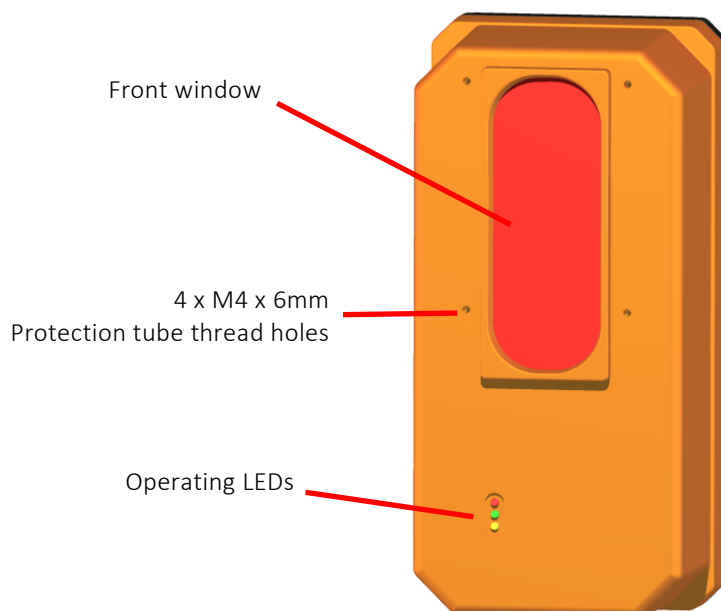

Figure 4: PAC250-90-y-zz+ Laser Scanners front side

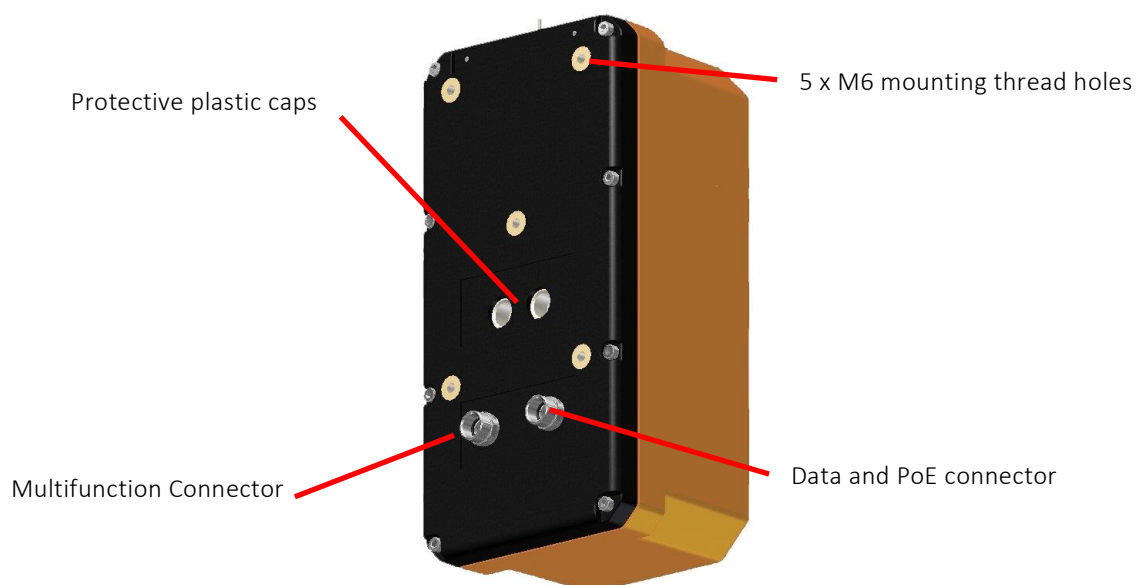

Figure 5: PAC250-90-y-zz+ Laser Scanners rear side



Caution

Do not ever remove the two plastic caps on the back plate!

Red Laser Marker (RLM)

RLM is a visible class-2 laser. The red laser beam is aligned with the beam of the measurement laser.

Measurement Laser

Emits a 905 nm invisible laser beam.

Receiver

Contains a receiver diode and is connected to the KEM-IC.

Measurement Processing Unit (MPU)

Contains a microcontroller and a Triple-IN KEM-IC chip to record time-of-flight events.

Application Processing Unit (APU)

It is a processing board with Linux OS, providing the Ethernet functionality and the option to run customized applications directly inside of the sensor.

Angle Encoder

It is an encoder with a resolution of 32000 coder counts.

Mirror cube

Reflects the laser beam. The 2D profile is generated due to its rotation.

Motor unit

Drives the mirror cube with a constant rotation frequency. The motor can be switched off by software.

Digital outputs

Two configurable isolated switching outputs are available, with a voltage working range from 3.3 VDC to 5 VDC.

Digital inputs

Two configurable digital inputs are available, in the same voltage range of the digital outputs. One of them can be configured to be used as a PPS (Pulse Per Second) signal for time synchronization.

Heater

The heater extends the temperature working range to -30° Celsius.

External incremental encoder interface

It is a 3.3 - 5 Volt input for a 32 bits counter used to provide a horizontal position from an external encoder.

4.2 Point of origin and scan area

PAC250-90-y-zz+ Laser Scanners trigger 1000 laser beams on a 90° scan field:

- The angle encoder zero-direction is to vertical axis of the sensor.
- The scan field starts at angle encoder position 45° and ends after 90° at encoder position 135° .
- The center point of a scan (point 500 in Normal Scan Mode) is located on the horizontal position.

The zero point (origin of the measurements) is marked on the casing with a black dot. The laser source is located with a parallax of 17 mm beside the vertical axis.

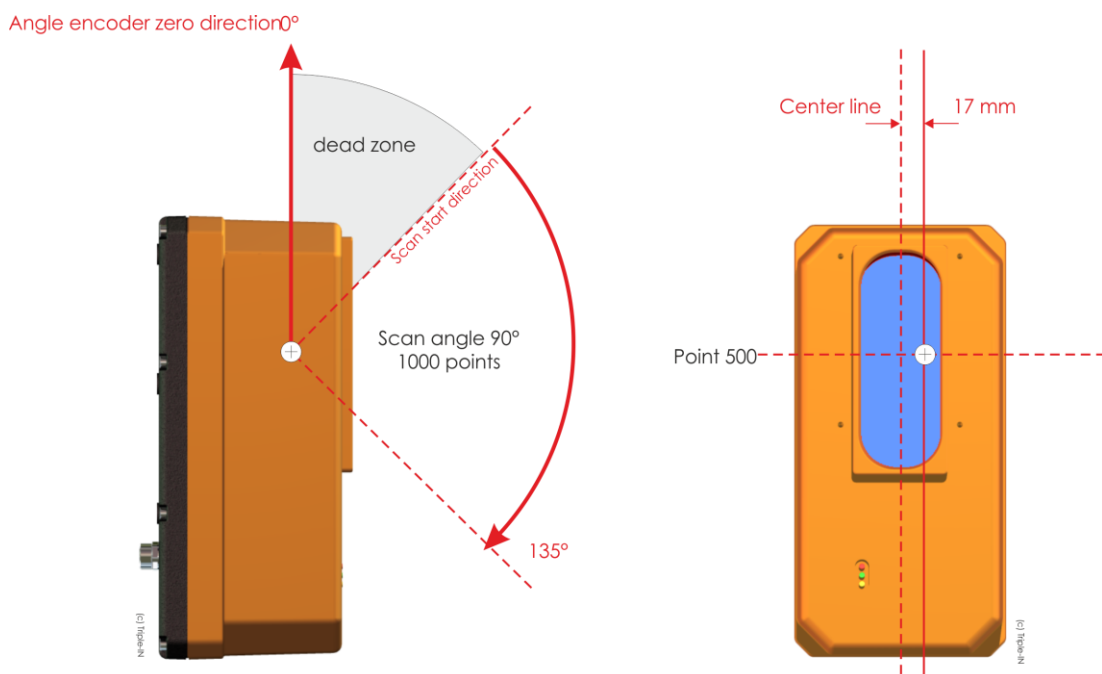

Figure 6: PAC250-90-y-zz+ Laser Scanners scan area and point of origin

The sensor contains a cube with four mirror surfaces, which is tilted on the rotation axis to build four scan lines.

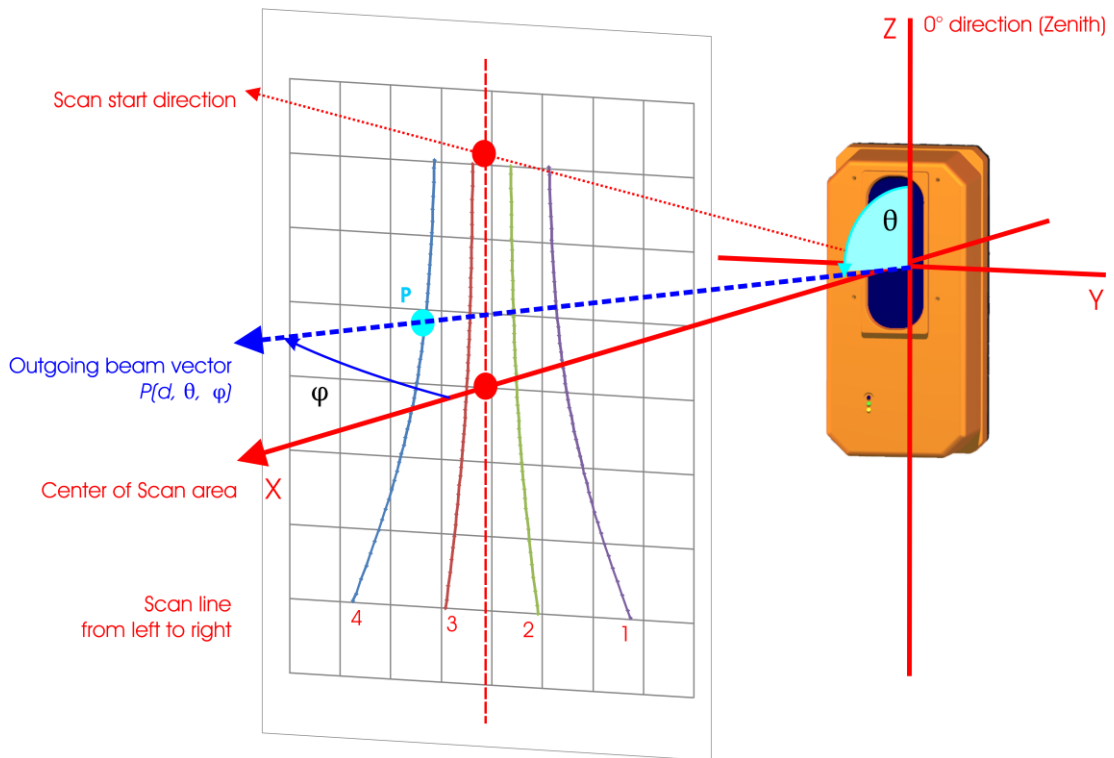

Figure 7: Scan Area

The scan field is defined by the following user settings:

- Profile start direction: vertical encoder reading to the direction where the profile starts.
Note that this angle position is different to the actual geometry of the the outgoing beam, because the laser beam is reflected on a tilted mirror cube.
- The scan angle defines the number of points in each scan.
- Scan lines: the four mirror surfaces produce the four scan lines one after the other in the order 1-3-4-2.

The mirror tilt angle and the laser beam reflection on the mirror surface lead to unique vertical and horizontal angles for each outgoing laser beam.

5 Transport, installation and maintenance

5.1 General handling instructions

- Ensure during the installation that the entire system is disconnected from power supply.
- Mount the PAC250-90-y-zz+ Laser Scanners at a location where the device is protected from damages, pollution and high humidity.
- Mount the PAC250-90-y-zz+ Laser Scanners in a way that it is not exposed to direct sunlight.
- Route cables such that danger is excluded for persons and all cables are protected from damages.
- Do not remove the label or the two gray plastic caps from the rear side.
- Follow the safety instructions in [Chapter 2](#).

5.2 Packaging and transport

PAC250-90-y-zz+ Laser Scanners are optical instruments. Such equipment must be transported with special caution and sufficient packaging to protect the sensors from possible damage.

Use original Triple-IN packing material to transport the sensor.

Two deepings at the top side indicate the upper foam inlet.



Figure 8: Packaging



Warning

Your warranty may be voided if returned sensor is received with inadequate packaging. Please always use the same package you received from Triple-IN for sending the sensor back.

At the time of delivery, the user should examine the shipment for loss or damage. If there is evidence of loss or damage, note it on the delivery receipt; this will be used as evidence to back up the claim. Do not use or install a defective device.

5.3 Condensation avoidance

If the PAC250-90-y-zz+ Laser Scanners are suddenly brought in from the cold into a warm room, condensation may form on the optics, and internal parts. To prevent condensation, first put the sensor in the transport box, then in a sealed plastic bag and let it adjust to the warmer temperature before taking it out of the bag.

If condensation forms on the sensor, do not use the sensor. This is to avoid damages to the electronics. If there is condensation, remove the power supply from the sensor, and wait until the condensation has evaporated.

5.4 Cleaning

PAC250-90-y-zz+ Laser Scanners are mainly free of maintenance. The front window must be checked regularly and must be cleaned from dust and dirt.

- Use a clean and moistened cloth to clean the body.
- Use a microfiber cloth to clean the front window. Don't put pressure on the cloth while cleaning the front window.



Warning

Don't use abrasives, household cleaners, or other aggressive liquids.

5.5 Mechanical integration

PAC250-90-y-zz+ Laser Scanners can be fitted at the rear side with five socket head screws with washers.

- Maximum Screw-in depth is max. 10 mm.
- Minimum screw-in depth is 4 mm.
- Maximum tightening torque is 12 Nm.

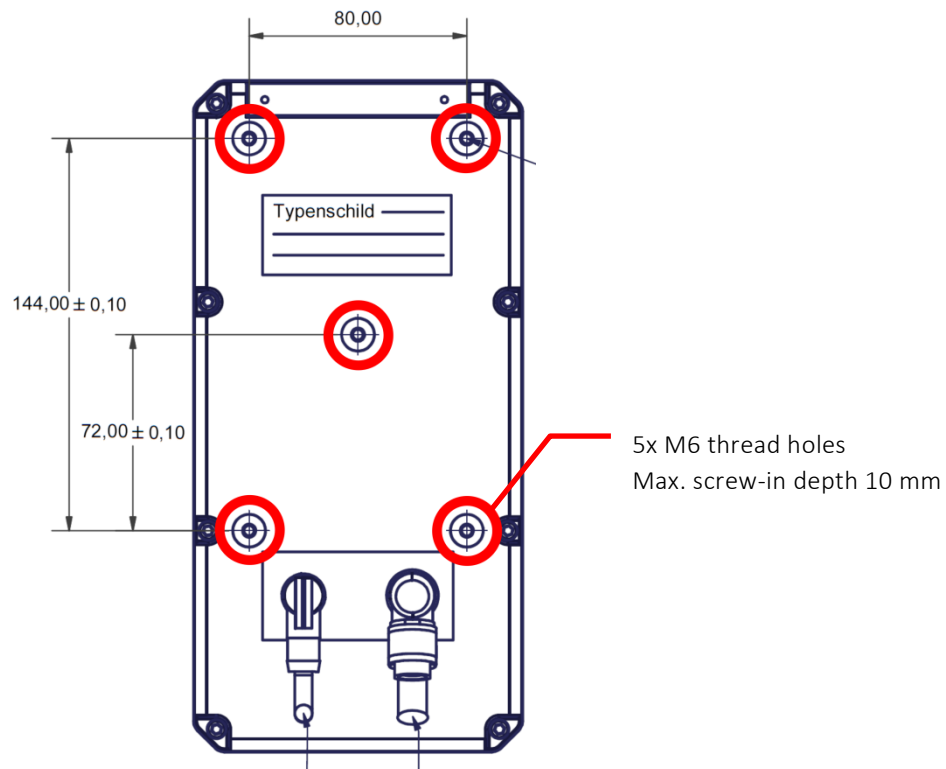

Figure 9: Mounting thread holes



Caution

Use correct M6 screws only.
Apply washers. The sensor must be fixed with at least four mounting screws.
Observe the maximum screw-in depth for the screw holes. The device will be mechanically destroyed if the maximum screw-in depth is exceeded!
Do not extend the maximum tightening torque of 12 Nm.

6 Connectors

6.1 Phoenix SPEEDCON® quick locking system



Warning

Before attaching the connectors, make sure the sealing rubber rings in the sockets are all in place.

Always fit sealing connector caps onto plugs which are not used.

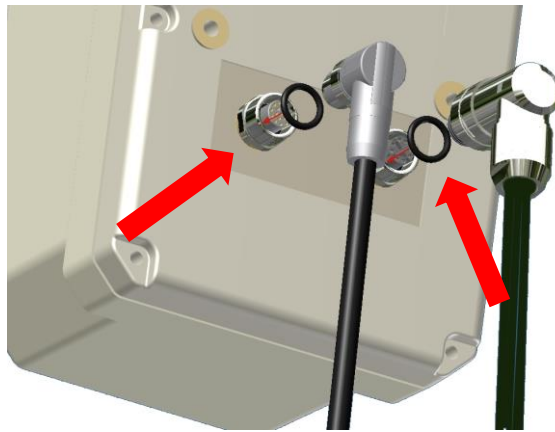

Figure 10: Connector rubber gasket

PAC250-90-y-zz+ Laser Scanners are equipped with Phoenix SPEEDCON® M12 quick locking connectors.

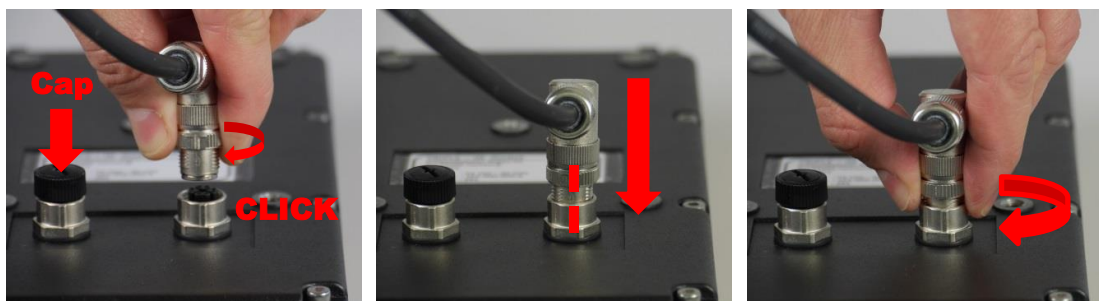

Figure 11: Using the quick locking connectors

1. Make sure the rubber gaskets in the sockets are in place.
2. Turn the retainer ring until you notice a distinct “click”.
3. Align marks at the retainer ring and the socket.
4. Push the connector into the socket.
5. Turn the retainer ring to secure the connection.

6.2 Data and PoE connector

6.2.1 Layout of the Data and PoE Connector

The Data and PoE Connector connects the sensor with the local network and includes Power over Ethernet.

- M12 connector/ IP67/CAT6 connector
- Type Phoenix Contact
“Flush-type socket - SACC-CI-M12FS-8CON-L180-10G – 1402457”
- Adapter type reference is Phoenix Contact
“Bus system plug connector - VS-08-M12MR-10G-P SCO – 1417443”

The pin/pair assignment conforms with the T568B standard.

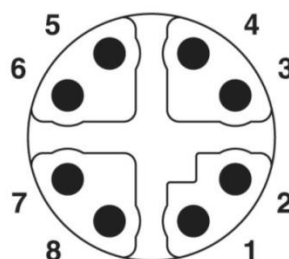

Figure 12: M12 Data and PoE scheme (plug side view)

Pin	Colour	Signal	Purpose
1	White/Orange	TX+	Transmit
2	Orange	TX-	Transmit
3	White/Green	RX+	Receive
4	Blue	24VDC+	Positive supply voltage
5	White/Blue	24VDC+	Positive supply voltage
6	Green	RX-	Receive
7	White/Brown	24VDC-	Negative supply voltage

Pin	Colour	Signal	Purpose
8	Brown	24VDC-	Negative supply voltage

6.2.2 Power over Ethernet (PoE)

PAC250-90-y-zz+ Laser Scanners use the Power over Ethernet (PoE) technology. PoE systems pass electrical power along with data on Ethernet cabling. This allows a single cable to provide both data connection and electrical power.



Caution

Power-over-Ethernet (PoE) and Multifunction connector are cross-linked. The power lines on the Multifunction connector become outputs if PoE is used. The Ethernet interface of the control computer shall be protected by an Ethernet Splitter to prevent short circuits if power is connected to the serial interface connector.

These input/output lines were originally designed to provide power to an external device, such as a turn table. These output lines must not be used with PAC250-90-y-zz+ Laser Scanners.

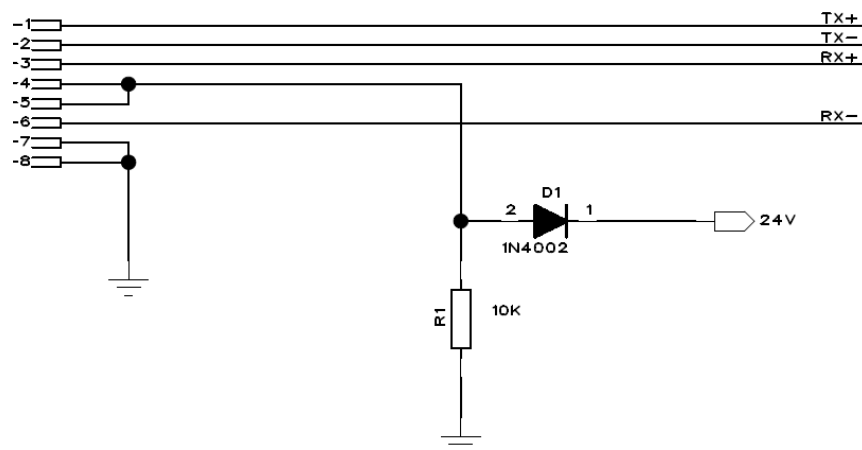

Figure 13: Scheme of the cross-linked power connectors



Warning

To reduce the risk of electric shock and damages, use suitable PoE devices and CAT6 Ethernet cables.

The PoE injector is not part of the PAC250-90-y-zz+ Laser Scanners delivery.

6.3 Multifunction Cable connector

6.3.1 Layout of the Multifunction Cable connector

The Multifunction cable connects the control computer with the RS232 interfaces of the Ethernet board and the measurement board.

The connector type is M12 connector/IEC 61076-2-101.

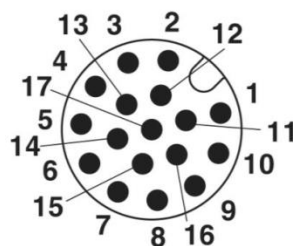

Figure 14: M12 Multifunction cable connector scheme (plug side view)

Pin	Colour	Signal	Comment	Direction
1	Brown	24 VDC-	Ground	-
2	Blue	24 VDC+	Positive power supply voltage	-
3	White	GND	RS232 ground	-
4	Green	-	Reserved for future use	Do not connect
5	Pink	ORX	RS232 RxD Application Programmable Board	
6	Yellow	OTX	RS232 TxD Application Programmable Board	
7	Black	-	Reserved for future use	Do not connect
8	Gray	-	Reserved for future use	Do not connect
9	Red	IN1	Isolated digital input	Input
10	Purple	IN2	Isolated digital input	Input
11	Gray/Pink	CH_A	External incremental encoder, channel A	Input

Pin	Colour	Signal	Comment	Direction
12	Red/Blue	CH_B	External incremental encoder, channel B	Input
13	White/Green	VCC_IO	Supply voltage for I/O, 3.3VDC to 5VDC	Input
14	Brown/Green	OUT2	Isolated digital switching output	Output
15	White/yellow	OUT1	Isolated digital switching output	Output
16	Yellow/Brown	STD_RXD	RS232 RxD Measurement Board	Input
17	White/Grey	STD_TXD	RS232 TxD Measurement Board	Output



Caution

If Pin 1 and 2 are used for power supply, the Power-over-Ethernet connection (PoE) must be disconnected by use of a PoE splitter.
Otherwise there can be a short circuit in the Ethernet connector to the gateway.



Warning

In the table, any grey field marks a pin reserved for future extension.
Do not connect these signals!

6.3.2 Power over the Multifunction connector

The Multifunction connector includes 24 Volt power lines cross linked with the PoE adapter. These input lines are designed to supply power over the serial interface connector.



Power supply

Without heater: 24 Volt, 0.33 Ampere, 8 Watt
With optional heater: 24 Volt, 1.35 Ampere, 33 Watt

6.3.3 Wiring the MPU RS232 Serial Interface

The Multifunction cable includes RS232 to the MPU.
The RS232 interface to the MPU is used for system configuration, e.g. to setup the network parameter.

PAC250-90-y-zz+ Laser Scanners are classified as Data Terminal Equipment (DTE). According to the standard, PAC250-90-y-zz+ Laser Scanners shall be equipped with male connectors.

A “null modem cable” consisting only of transmit data, receive data, and ground, is commonly used since the full facilities of RS232 are not required.

A DSUB9 connector must connect the following leads:

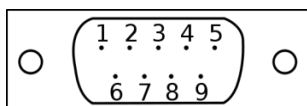

Figure 15: MPU DSUB9 male DTE pin layout (socket view)

DSUB9 pin	Connector	Name	Signal
3	17	STD_TXD	RS232 MPU transmit
2	16	STD_RXD	RS232 MPU receive
5	3	GND	Common ground

6.3.4 Wiring the APU RS232 Serial Interface

The Multifunction cable includes the RS232 to the the APU.

The APU board provides the Ethernet interface. The RS232 interface is only used as a console access to the Linux system.

PAC250-90-y-zz+ Laser Scanners are classified as Data Terminal Equipment (DTE). According to the standard, PAC250-90-y-zz+ Laser Scanners shall be equipped with male connectors. A “null modem cable” consisting only of transmit data, receive data, and ground, is commonly used since the full facilities of RS232 are not required.

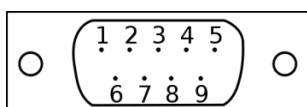

Figure 16: APU DSUB9 male DTE pin layout (socket view)

DSUB9 pin	Connector	Name	Signal
2	5	ORX	RS232 Communication board receive
3	6	OTX	RS232 Communication board transmit
5	3	GND	Common ground

6.3.5 Wiring Digital Outputs

PAC250-90-y-zz+ Laser Scanners have two isolated digital switching outputs, called OUT1 and OUT2. These outputs can be programmed for different purposes.

- Maximum output current is 50 mA;
- Maximum voltage to be applied is 5 V;
- Output residual voltage is < 1 V;
- Power supply range at VCC_IO is 3.3 to 5 VDC (+/- 10%).

Connector	Name	Signal	Purpose
15	OUT1	Digital output 1	Digital switching output
14	OUT2	Digital output 2	Digital switching output
13	VCC_IO	Digital output support voltage	Support voltage for the digital inputs and digital outputs
1	24V DC-	Power supply	Ground

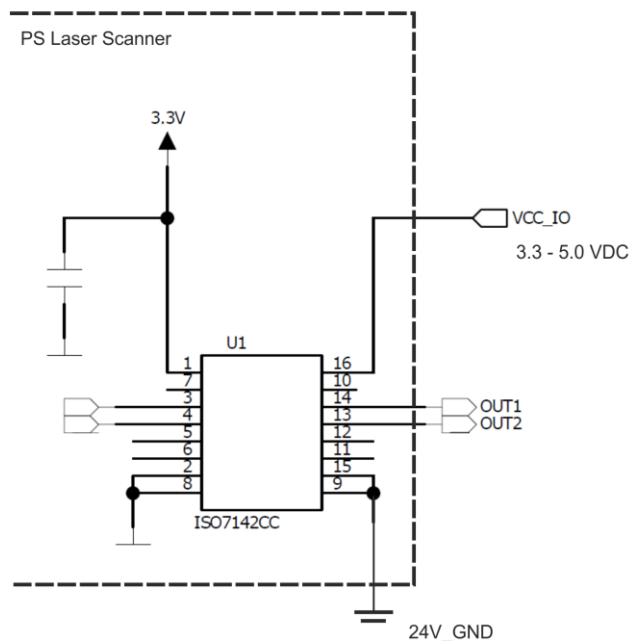

Figure 17: Digital outputs wiring scheme

6.3.6 Wiring Digital Inputs

PAC250-90-y-zz+ Laser Scanners have two digital inputs, called IN1 and IN2. These inputs can be programmed for different purposes.

- Inputs are TTL;
- Maximum voltage to be applied is 5 V;
- Output residual voltage is < 1 V;
- Power supply range at VCC_IO is 3.3 to 5 VDC (+/- 10%).

Connector	Name	Signal	Purpose
9	IN1	Digital input 1	Digital input
10	IN2	Digital input 2	Digital input
13	VCC_IO	Digital output support voltage	Support voltage for the digital inputs and digital outputs
1	24V DC-	Power supply	Ground

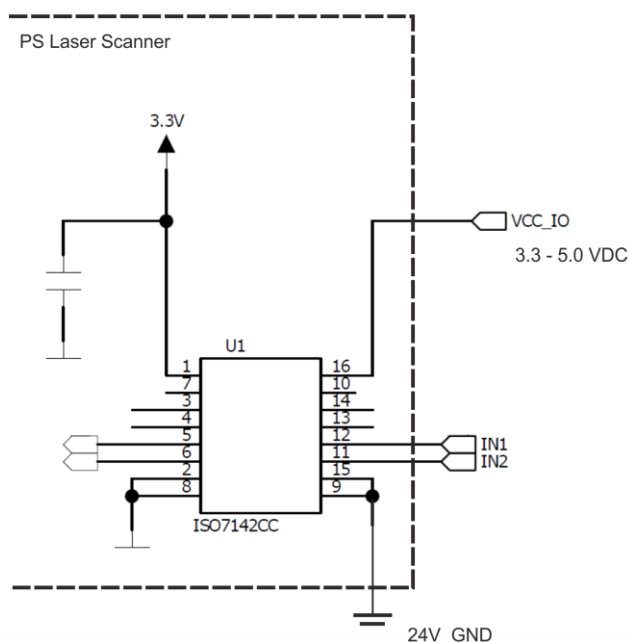

Figure 18: Digital inputs wiring scheme

6.3.7 Wiring an external incremental encoder

The PAC250-90-y-zz+ Laser Scanners provide one 3.3 to 5.0 Volt incremental encoder input. Purpose of the external incremental encoder is to report changes in the horizontal position of the sensor.

The incremental encoder must provide two pulses A and B. The PS Sensor firmware counts these pulses in both directions by use of 32 bits register.

Input is limited to 128.000 counts/second.

Reset of the counter is done at startup or by software.

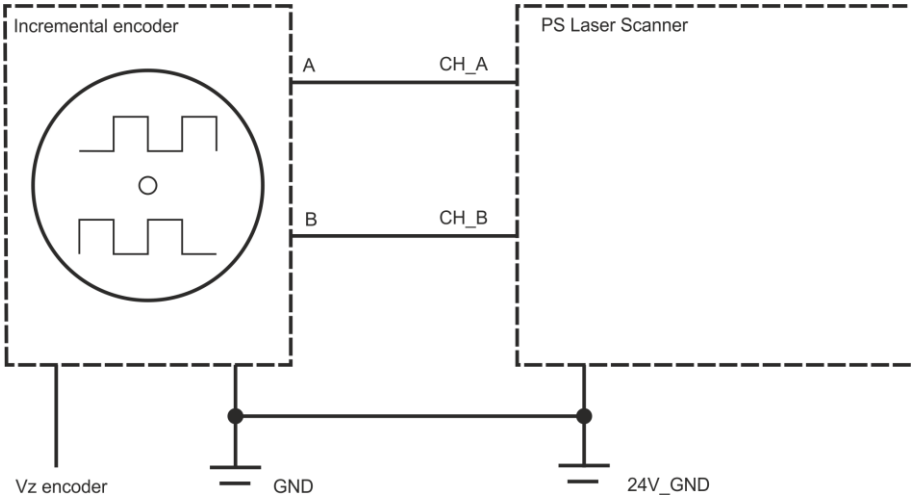

Figure 19: Incremental encoder wiring scheme

7 Microsoft Windows Software Tools

7.1 TeraTerm for the RS232 Serial Interface

TeraTerm is a very suitable program for the so-called Terminal Mode of the PAC250-90-y-zz+ Laser Scanners. TeraTerm (author: T. Teranishi) is a free software terminal emulator and serial communication program for Windows.

Any other terminal program will be suitable as well.

1. Download TeraTerm from Triple-IN's web server.
2. Run the TeraTerm program installer.
3. Connect the EDM via a RS232 connection, using either a generic COM port or an USB-to-serial adapter.
4. Open TeraTerm and navigate to "Setup > Serial port..."
5. Choose the correct COM port.
6. Set the baud rate to 115200, 8 data bits, no parity, 1 stop bit, no flow control.

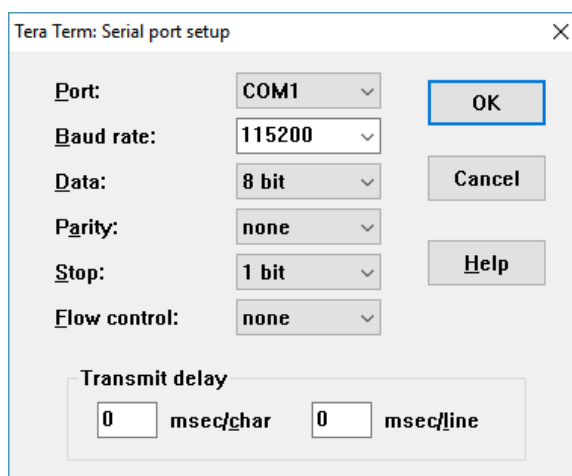

Figure 20: TeraTerm Serial Port setup dialog

7. Close the setup dialog.
8. If you want to store these settings for future use, go to "Setup > Save setup..."
9. Navigate to the TeraTerm installation directory and store the setup in TERATERM.INI.

7.2 TCP/IP Manager for managing network configurations

Triple-IN recommends the open-source Freeware “TCP/IP Manager” (author: A. C. Tundra) to prepare the computer’s network settings for PAC250-90-y-zz+ Laser Scanners. With this tool, you may simply save and restore network settings for PAC250-90-y-zz+ Laser Scanners and standard Windows applications in different profiles.

1. Download TCP/IP Manager from Triple-IN’s web server.
2. Run the installer resp. unpack the ZIP file.
3. Start TCP/IP Manager.
4. Select in “TCP/IP Settings > Network connection name” the network adapter connected with the sensor.
5. Check if “IP address” matches the Gateway IP address as stored in the sensor. The default Gateway address is 10.0.10.0.
6. Check if “Subnet mask” matches the subnet mask as stored in the sensor. The default network mask is 255.255.0.0.
7. For later use, consider “Network profile > Create a new profile” to save the setup.
8. Choose “Apply Settings”.
9. To connect a sensor with the default settings:

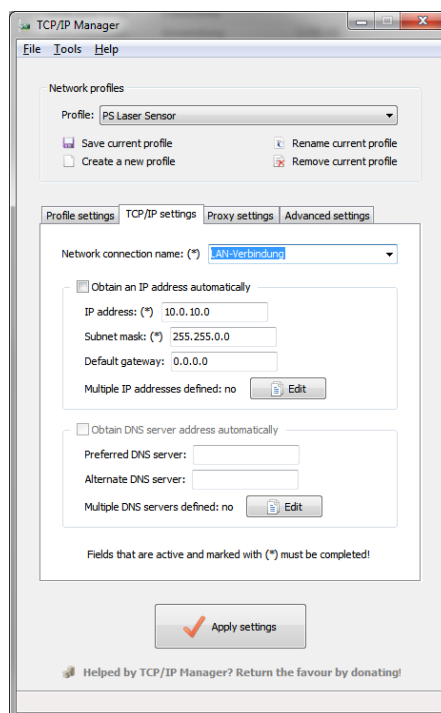

Figure 21: Network configuration with TCP/IP Manager

After disconnecting the sensor, you may use TCP/IP Manager to restore the Windows standards:

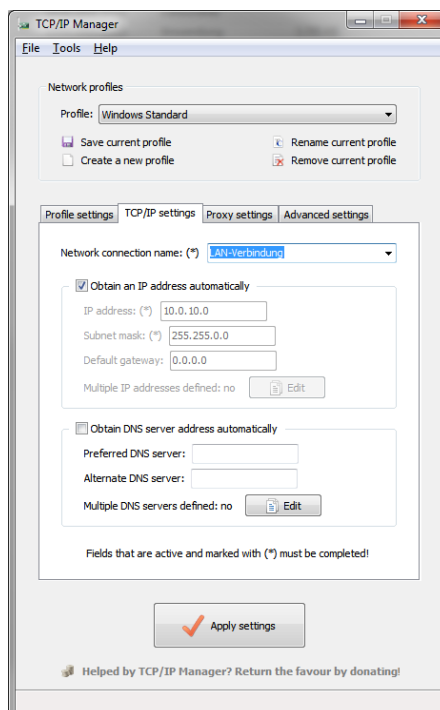

Figure 22: Restore the network configuration with TCP/IP Manager

1. Start TCP/IP Manager.
2. Select in “TCP/IP Settings > Network connection name” the network adapter connected with the sensor.
3. “Obtain an IP address automatically” should be checked.
4. For later use, consider “Network profile > Create a new profile” to save the setup.
5. Choose “Apply Settings”.

7.3 Triple-IN PSControlProgram

Triple-IN’s PSControlProgram is a PC application for controlling the functionality of Triple-IN Laser sensors via Ethernet connection. It makes the user able to set the user parameters of the sensor, start measurements, record the scans to files or show it on the chart or in the table.

The program is available on Triple-IN’s web server.

7.3.1 Installation

To install the application please follow the instructions:

1. Start Windows installation program.
2. Confirm that you have administrator permissions to install the program.
3. The installer inspects the version information to use it during the installation process.
4. The product information (company, product name and version) is displayed on the screen if it's found during the analysis process.
5. Confirm installation.

A full description of the program can be found in the "PSControlProgram User's manual". The manual is part of the program distribution.

8 Setting into operation

8.1 Startup Procedure

To start the system:

- Connect the control computer to the same network of the PAC250-90-y-zz+ Laser Scanners.
- Connect the power supply to the PAC250-90-y-zz+ Laser Scanners.
- After switching on the supply voltage, the scanner runs through a self-test. All LEDs are flashing. The firmware of the device checks important hardware components and parameters. Commands will respond to the control computer with a “device not ready” error.
- The red LED is switched off after the self-test has passed successfully.



Important

After disconnecting the sensor from power supply, you must wait 30 seconds before turning it back on. Otherwise capacitors not being discharged could leave the sensor peripheral not fully reset.

8.2 Serial RS232 Communication

8.2.1 Setting up the serial communication

PAC250-90-y-zz+ Laser Scanners have serial RS232 interfaces to connect a control computer with the MPU. The standard communication settings are:

Parameter	Value
Baud rate	115200 bauds
Data bits	8
Parity	None
Stop bits	1
Handshake	No hardware or software handshake

The first serial interface, internally connected with the MPU, is used to program the TCP/IP connection parameters and to update the MPU firmware. This interface supports the so-called Terminal Mode (see next paragraph). After start-up, the terminal displays the sensor's serial number, IP address and self-test results.

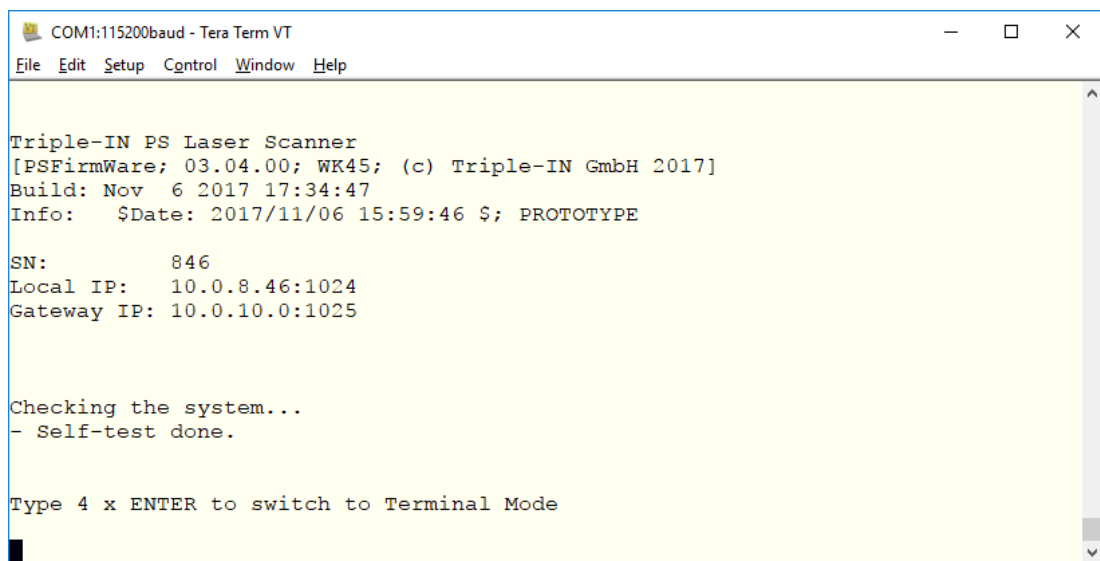

```
COM1:115200baud - Tera Term VT
File Edit Setup Control Window Help

Triple-IN PS Laser Scanner
[PSFirmWare; 03.04.00; WK45; (c) Triple-IN GmbH 2017]
Build: Nov 6 2017 17:34:47
Info:  $Date: 2017/11/06 15:59:46 $; PROTOTYPE

SN:      846
Local IP: 10.0.8.46:1024
Gateway IP: 10.0.10.0:1025

Checking the system...
- Self-test done.

Type 4 x ENTER to switch to Terminal Mode
```

Figure 23: MPU start-up message

The second serial interface is connected to the APU and is used to access the Linux console.

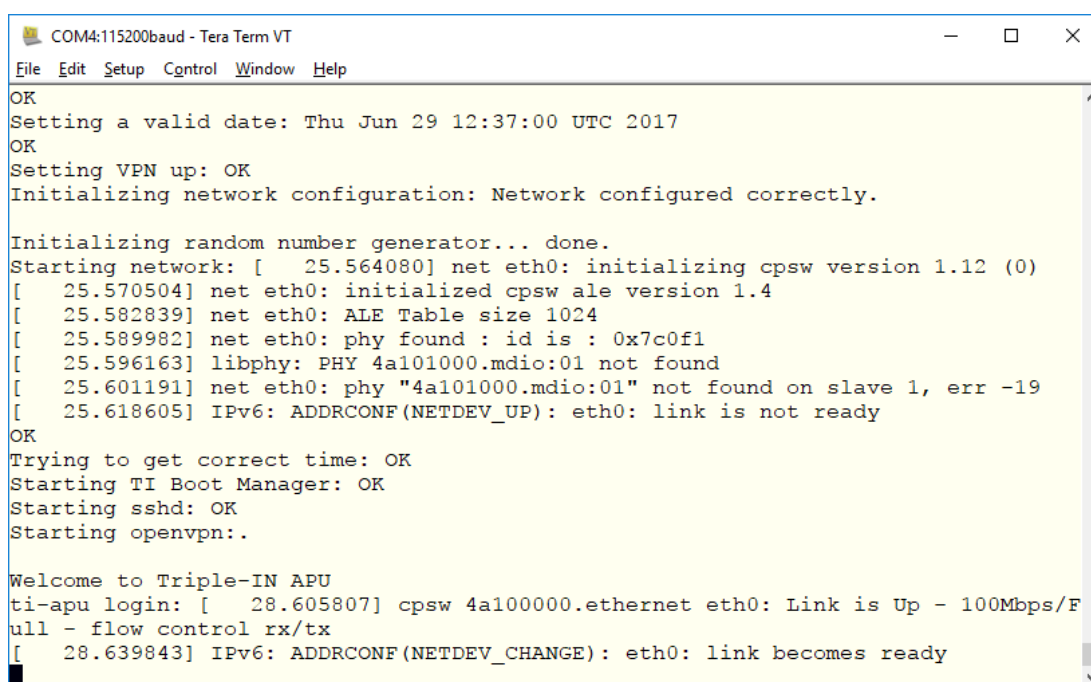

```
COM4:115200baud - Tera Term VT
File Edit Setup Control Window Help
OK
Setting a valid date: Thu Jun 29 12:37:00 UTC 2017
OK
Setting VPN up: OK
Initializing network configuration: Network configured correctly.

Initializing random number generator... done.
Starting network: [ 25.564080] net eth0: initializing cpsw version 1.12 (0)
[ 25.570504] net eth0: initialized cpsw ale version 1.4
[ 25.582839] net eth0: ALE Table size 1024
[ 25.589982] net eth0: phy found : id is : 0x7c0f1
[ 25.596163] libphy: PHY 4a101000.mdio:01 not found
[ 25.601191] net eth0: phy "4a101000.mdio:01" not found on slave 1, err -19
[ 25.618605] IPv6: ADDRCONF(NETDEV_UP): eth0: link is not ready
OK
Trying to get correct time: OK
Starting TI Boot Manager: OK
Starting sshd: OK
Starting openvpn:.

Welcome to Triple-IN APU
ti-apu login: [ 28.605807] cpsw 4a100000.ethernet eth0: Link is Up - 100Mbps/F
ull - flow control rx/tx
[ 28.639843] IPv6: ADDRCONF(NETDEV_CHANGE): eth0: link becomes ready
```

Figure 24: APU startup message

8.2.2 Entering the Terminal Mode

The PAC250-90-y-zz+ Laser Scanners provides a Terminal Mode as an additional user interface.

This is an ASCII oriented, human-readable menu structure and user interface.

The Terminal mode is entered after the user sends 4 successive carriage return characters from a RS232 terminal console.



Note

The Ethernet interface is not available while the sensor operates in the Terminal Mode.

```
Terminal Mode

1 - Show user parameter
2 - Show system health status
3 - Network configuration ...
4 - Restore to factory settings
5 - Show reference tables...

E - Edit parameter
S - Take a scan
L - Switch laser marker

0 - Exit to Run Mode
```

Figure 25: MPU terminal mode

Show user parameter

Lists the parameters set by the user. With the function "Edit parameter" these values can be edited.

Show system health status

Lists the results of the self-test. See Appendix A for information about the meaning of the single statuses.

Network configuration

Changes the IP settings to standard configurations.

Restore to factory settings

This function is used to set parameters to their default values.



Important

All previously modified parameter values will be lost.

Show reference tables

Displays the firmware versions and parameter code reference tables.

Edit parameters

This function is used to change any parameter. The parameter codes are needed for this. After entering the parameter code, the firmware shows the current value, the measurement unit and the valid range of values. The program then asks whether the changed parameters should be stored in the flash.

```
> E
> Enter parameter ID:
3_

> Enter parameter "Scan mode: 0=off, 1=normal, 2=fast, 3=fine,
4=reserved;":
2_
```

Figure 26: Editing a parameter in Terminal Mode

Take a scan

Starts the motor and carries out a single scan. The result is presented as CSV table. This function shall be used to check the basic functionality of the sensor.

Switch laser marker

Switches the red laser marker on and off.

8.2.3 Binary Command/Control Interface

Control computer programs, such as PSControlProgram, communicate with PAC250-90-y-zz+ Laser Scanners over Ethernet or serial RS232 by use of binary commands. A full reference of the binary command/control interface can be found in the "PS Plus Programmer's Manual".

8.3 Ethernet connection

8.3.1 Network settings

PAC250-90-y-zz+ Laser Scanners use the Internet Socket Interface for communications over Ethernet. The sensor socket address is a combination of the IP address (the location of the sensor) and a port (which is mapped to the application program process) into a single identity.

8.3.2 UDP/IP transport protocol

The UDP transport protocol can be used to send commands to the sensor, receive responses and receive the online scan stream.

8.3.3 TCP/IP transport protocol

The TCP transport protocol can be used to send commands to the sensor and receive responses. It is possible but not recommended to use TCP/IP to receive online scan stream.

8.3.4 Why choose UDP for scan data stream

TCP was designed to be reliable in data transmission. This means that, if a packet of data is not correctly (without errors) received by the destination, the sender will try to transmit it again until it is received correctly.

In a real-time system though it is more important to have always the most recent data available even if it means to have some previous data lost.

The UDP transport protocol has a lot of advantages for this purpose:

- It is stateless, suitable for very large numbers of clients. It is used for example in streaming media applications such as IPTV
- The lack of retransmission delays makes it suitable for real-time applications such as Voice over IP, online games, and many protocols built on top of the Real Time Streaming Protocol
- It works well in unidirectional communication and is suitable for broadcast information such as in many kinds of service discovery and shared information such as broadcast time or Routing Information Protocol

All these attributes (and more) made the UDP protocol the best choice to send the scan data stream to the requesting consumers.

8.3.5 Sensor IP address, Client IP address, Gateway IP and port

In the described communication pattern, the sensor provides some functionalities accessible through the Ethernet. Each one of these functionalities is identified as a "Service", and the control computer is the "Client".

The sensor has the possibility to start sending a scan data stream automatically on power on to a predefined Client, identified as the "Gateway" by a user defined combination of IP address and port. This specific function is called **AutoStart** (more information can be found in the "PS Plus Programmer's Manual").

The sensor socket addresses are a combination of an IP address and a port (which is mapped to the application program process). Every available combination identifies a Service.

The sensor has two different IP addresses configured and exposed to the outside:

- **Predefined.** Is automatically calculated from the serial number and cannot be changed. The network mask is **255.255.0.0** and it is calculated this way:

```
IP = 10.255.(serial / 100).(serial % 100)
```

- **Custom.** This address can be modified by the user. It is initially set with a default value calculated similarly to the Predefined:

```
IP = 10.0.(serial / 100).(serial % 100)
```

8.3.6 Timeout

The command interface of the firmware has following timeouts:

- for measurement requests: **5** seconds
- for measured scans: **30** seconds
- for changing parameters: **60** seconds

The sensor sends an error (**ERR\0**) response if a timeout has occurred.

8.3.7 Sensor features announcement

The PAC250-90-y-zz+ Laser Scanners can send a message containing information about the configuration of the sensor itself. This is useful to discover the IP addresses of one or more sensors connected to a network.

To receive this message, it is necessary to broadcast a specific command to the sensors network on a specific port.

Details on this protocol are defined later in this document.

8.3.8 Services

The following are the services available by default on a sensor. As an example, we list the IP addresses for a sensor with the serial number as **1234**:

Service IP/Port	Protocol	Service	Description
10.255.12.34 6969	TCP/IP	Scan and commands	Command communication line for configuration and online data stream
	UDP/IP	Scan and commands	Command communication line for configuration and online data stream
10.0.12.34 1024	TCP/IP	Scan and commands	Command communication line for configuration and online data stream
	UDP/IP	Scan and commands	Command communication line for configuration and online data stream

Service IP/Port	Protocol	Service	Description
0.0.0.0 6996	UDP/IP	Announcement	A defined command sent to this channel will respond with the announcement message
0.0.0.0 3007	TCP/IP	Update	Used to send firmware updates to the sensor
0.0.0.0 22	TCP/IP	SSH	SSH access to the sensor
0.0.0.0 80	TCP/IP	Web interface	Access to the sensor web interface

8.3.9 Concurrent connections

Update and Commands TCP/IP listening Services are limited to one connection at a time. This means that if a TCP/IP Service is connected to a client, no other Client can use that service.

8.3.10 Custom Service IP and Port

The IP address set by the user cannot be the same as the Predefined.
The Port set by the user cannot be one of: **22**, **80**, **3007**, **6969** and **6996**.

8.3.11 Changing the Sensor's network configuration using the RS232 Terminal Mode

The sensor IP address and the Gateway IP address can be set in the RS232 Terminal Mode with the parameters **"Sensor IP address"**, **"Gateway IP address"**, and **"IP Subnet Mask"**.

The Terminal Mode includes a function **"3 - Network configuration ..."** for a simple IP setup. The following configurations are available and can be changed individually:

```
Network configuration menu

Sensor IP address is 10.0.8.1
Gateway IP address is 10.0.10.0

1 - Set default sensor IP address
2 - Set static sensor IP address
3 - Set private sensor address (APIPA)
4 - Edit sensor IP address
5 - Edit Gateway IP address
6 - Edit network mask

0 - Exit
```

Figure 27: Network configuration in Terminal Mode

- Default sensor IP address which is created in address space 10.0.x.x according to the sensor serial number.
- A static sensor IP address which is 192.168.0.10 by default.
- Private sensor IP address (APIPA) which is 169.254.0.10 by default. APIPA addresses are for standalone Windows computers.

These IP settings can be changed individually after the default has been set:

```
> Enter Parameter "Sensor IP Address AAA.xxx.xxx.xxx":
192
> Enter parameter "Gateway IP Address xxx.BBB.xxx.xxx":
168
[...]
```

Figure 28: Network address edit in Terminal Mode



Note

- The sensor needs to be restarted after the network configuration has been changed.
- The Ethernet interface is disabled while the Terminal Mode is active.

8.3.12 Changing the Sensor's network configuration using PSControlProgram

PSControlProgram is useful to change the sensors' default network settings over Ethernet:

1. Start PSControlProgram.
2. Choose button "Connect" to connect the application with a sensor. The IP and port dialog appears on the beginning of the connection progress.
3. Enter the sensor's standard IP address and the computer's IP address. Note that both addresses must be part of the same network.

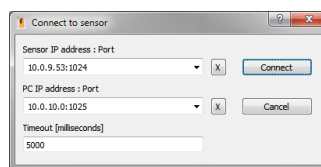

Figure 29: PSControlProgram network connection dialog

4. Once the connection has been made, all parameters including the network settings can be changed on the "Parameters" view.

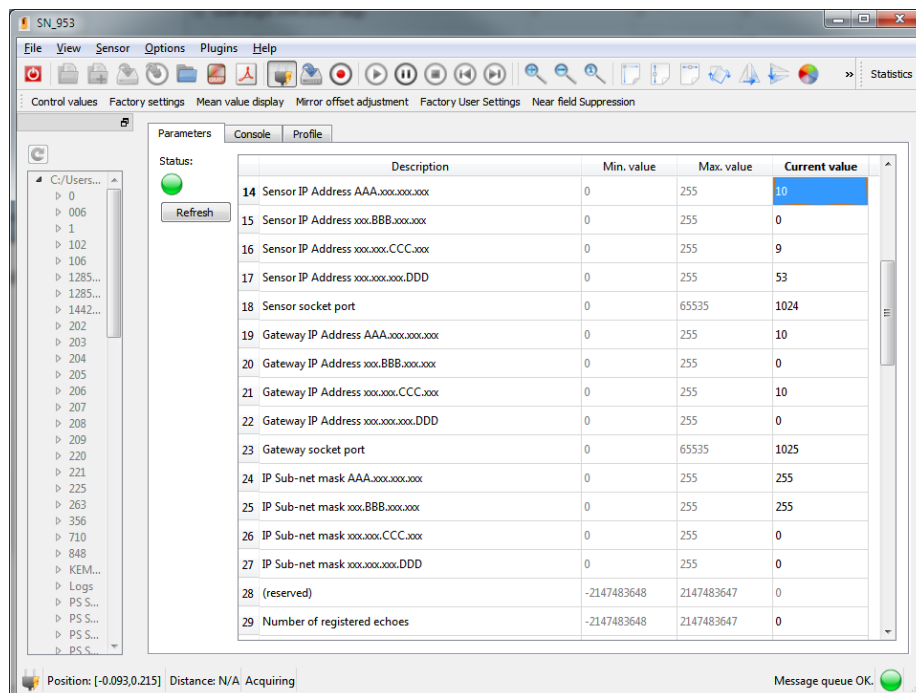

Figure 30: PSControlProgram parameter view

5. Switch-off and restart the sensor to apply the changed network settings.

8.4 Configuration

8.4.1 Ways of configuration

You can configure the PAC250-90-y-zz+ Laser Scanners in different ways:

- Using the commands “GPRM get parameter” and “SPRM set parameter” of the binary command/control interface. This way is most suitable for computer programs, such as PSControlProgram;
- Interactively using the RS232 Terminal Mode;
- Interactively using the sensor’s web interface.

8.4.2 About User Parameters

The entire sensor configuration is stored in a table of user parameters. Every parameter has a number as unique parameter identification code. The user can edit the parameter either by use of the Terminal Mode, or over RS232 and Ethernet by use of binary commands.

A list of parameters can be found in the “PS Plus Programmers Manual”.



Important

Parameter identifiers always refer to a certain firmware version. Therefore, an individual parameter reference table exists for every firmware version. You find the description of the binary commands for the processing of the user parameters in the “PS Plus Programmer’s Manual”.

8.5 Taking Scans

8.5.1 Setting up the Scan Mode

With each of the scan modes, the following measurement parameters are set:

- Scan rate: number of scans per second.
- Scan start direction: direction of the first measurement point of a scan.
- Scan angle: size of the scan area in degree.

- Scan angle step: small angle between two subsequent measurement points. Defined by the scan angle size and the number of measurement points.
- Scan Angle Shift: small angle between the start directions of subsequent scans.

The scan mode can be set with the user parameter:

```
Scan mode: 0=off, 1=normal, 2=fast, 3=fine, 4=reserved
```

Normal scan mode

The “Normal Scan Mode” is defined by the following parameters:

- Scan start direction: min. 45°
- Scan angle: max. 90° with 1000 points.
- Scan angle step: $90^\circ/1000 \text{ points} = 0.090^\circ$
- Scan Angle Shift: Normal-Mode scans are not shifted.

Fast scan mode

To achieve an increase on the scan rate, the point density must be reduced. In “Fast Scan Mode” the point density is halved, with the scan rate doubled accordingly.

- Scan start direction: min. 45°
- Scan angle: max. 90° with 500 points.
- Scan angle step: $90^\circ/500 \text{ points} = 0.180^\circ$
- Scan Angle Shift: Fast-Mode scans are not shifted.

Fine scan mode

If the scan rate is not important but the lateral resolution is, a shift between the scans may be introduced. This leads to more “scans/profile” and consequently to a better lateral resolution with overlapping spots and a reduced profile rate. This measurement mode is called “Fine Scan Mode” and is implemented by interlacing 4 Normal scan lines with 1/4 angle shift.

- Scan start direction: min. 45°.
- Scan angle: max. 90° with 4x1000 points interlaced.
- Scan angle step: $90^\circ/1000 \text{ points} = 0.090^\circ$ that will be interlaced.
- Scan Angle Shift: each scan is shifted by 0.0225° .
- Four scans can be interlaced to a single profile with 4000 points.

8.5.2 Taking scans in Terminal Mode

The Terminal Mode function “Take a scan” creates a table with the latest profile scan. The ASCII format is “comma separated” and can be easily imported into Excel or Open Office.

1. Enter the Terminal Mode
2. Open in TeraTerm “File > Log...”. Check “Plain text” and disable “Append”
3. Choose a log file name and close the dialog. TeraTerm will now record all sensor outputs
4. Choose “S – Take a Scan”
5. Close TeraTerm
6. The log file can be opened directly with a common spread sheet program like Excel or OpenOffice Calc

```

- Starting the motor...

Scan;
-----
375.877; Time Stamp [s] ;
    0; Incremental encoder position [counts];
45.000; Profile start direction [deg];
90.000; Scan angle [deg];
0.090; Angle step [deg];
1000; Points in profile ;
    0; Master echo (0=last echo);
    1; Number of echoes;
31.7; Temperature [Celsius];
-----
Point ;    Echo ;    Direction ;    Distance ; Pulse width ;
    ;        ;        [deg] ;        [m] ;        [ps] ;
-----
1 ;        1 ;        45.000 ;        2.4388 ;    9907 ;
2 ;        1 ;        45.090 ;        2.4305 ;    9895 ;
3 ;        1 ;        45.180 ;        2.4340 ;    9871 ;
4 ;        1 ;        45.270 ;        2.4437 ;    9772 ;
5 ;        1 ;        45.360 ;        2.4584 ;    9969 ;
6 ;        1 ;        45.450 ;        2.4401 ;   10019 ;
7 ;        1 ;        45.540 ;        2.4531 ;   10044 ;
8 ;        1 ;        45.630 ;        2.4698 ;   10129 ;
[...]
3000 ;    1 ;        314.910 ;        1.6629 ;    6465 ;

```

Figure 31: A scan taken in Terminal Mode

The header of the table contains:

- Time stamp [s]: is the time in seconds since the sensor was started
- Incremental encoder position [count]: is the count of the optional external incremental encoder.
- Profile start direction: is the start direction of the profile, where 0 is upwards to the zenith.
- Scan angle: is the scanned area in degrees.
- Angle steps: give the scan resolution in degrees.
- Points in profile: give the length of the following measurements table.
- Master echo: 1 for the first echo or 0 for the last echo.
- Number of echoes: the number of echoes processed.
- Temperature: is the reading from the internal temperature sensor in Celsius degrees.

The measurements table contains:

- Point: the number of the current point in the scan
- Echo: the number of the evaluated echo. This value is always 1 if the Master Echo parameter has been set to "1=first echo". The echo number varies from 1 to 4 if the Master Echo has been set to "0=last echo".
- Direction: direction to the target in degree.
- Distance: distance in meters to the target surface.
- Pulse width : echo signal pulse width in pico-seconds

8.5.3 Taking scans with Triple-IN's PSControlProgram

Triple-IN's PSControlProgram is a Windows application with user menu, toolbar, status line, workspace explorer bar and the data output widgets ordered in the tabs. User menu and main toolbar are providing the basic functionality for the system actions like connecting the program with a sensor, performing the scans, recording, loading or, exporting the data to "*.csv" files.

The program is available on Triple-IN's web server.

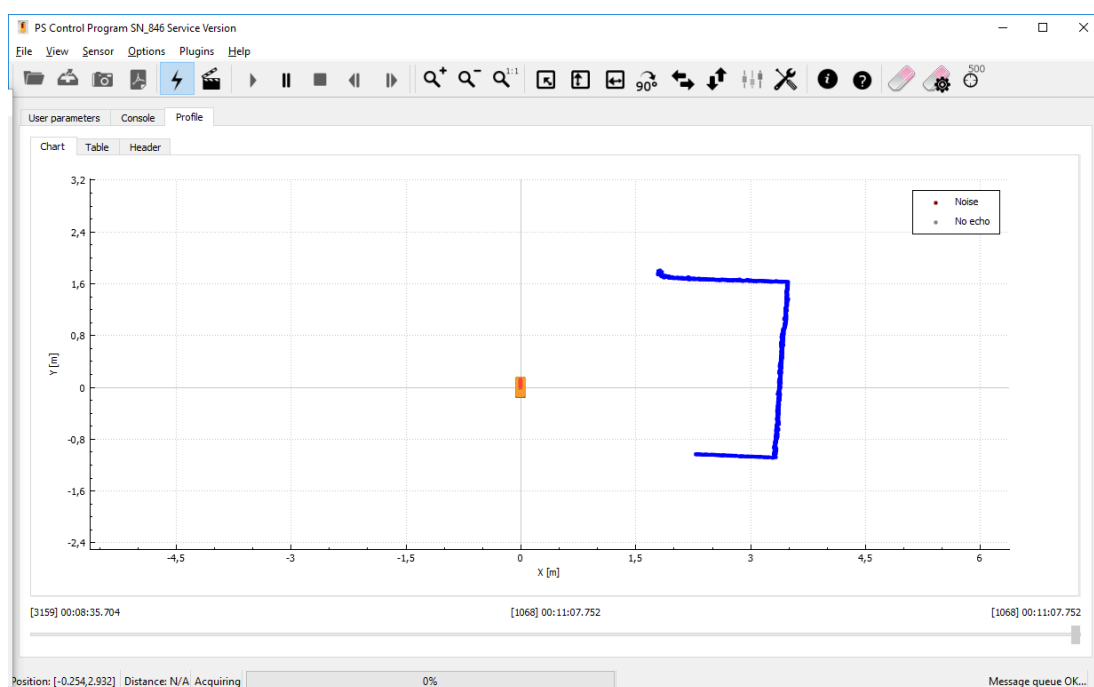

Figure 32: A scan taken with PSControlProgram

1. Connect to the sensor
2. Once online the record button allows the user to write the scans to the binary files for later evaluation
3. If the recording starts successfully the application starts to write the binary data to files. Every minute the new file for recorded files is created
4. To easily find the files press “Open output directory” button on the toolbar and a File explorer window will be opened pointing at the correct directory.

8.6 Measurement filters

8.6.1 Near field suppression filter

The near-field suppression is used to suppress measurements to targets close to the sensor. This prevents the sensor to detect contamination of the optics.

PAC250-90-y-zz+ Laser Scanners have optional, adjustable near-field suppression. This is divided up in zones, each with a width of 760 millimeter. Zone 0 defines the closest distance. The closest distance depends on the sensor model.

The near field suppression zone can be configured with the user parameter:

Triple-IN

Near-field suppression zone, min=0

The current near field range can be obtained by the parameter

Const: Near field suppression range [0.1 mm]

Example:

Zone 3 has been set as near field suppression range. Any echo from a target in the range will be ignored:

$\text{Near_field_range} = \text{zone0} + \text{zone1} + \text{zone2} + \text{zone3}$

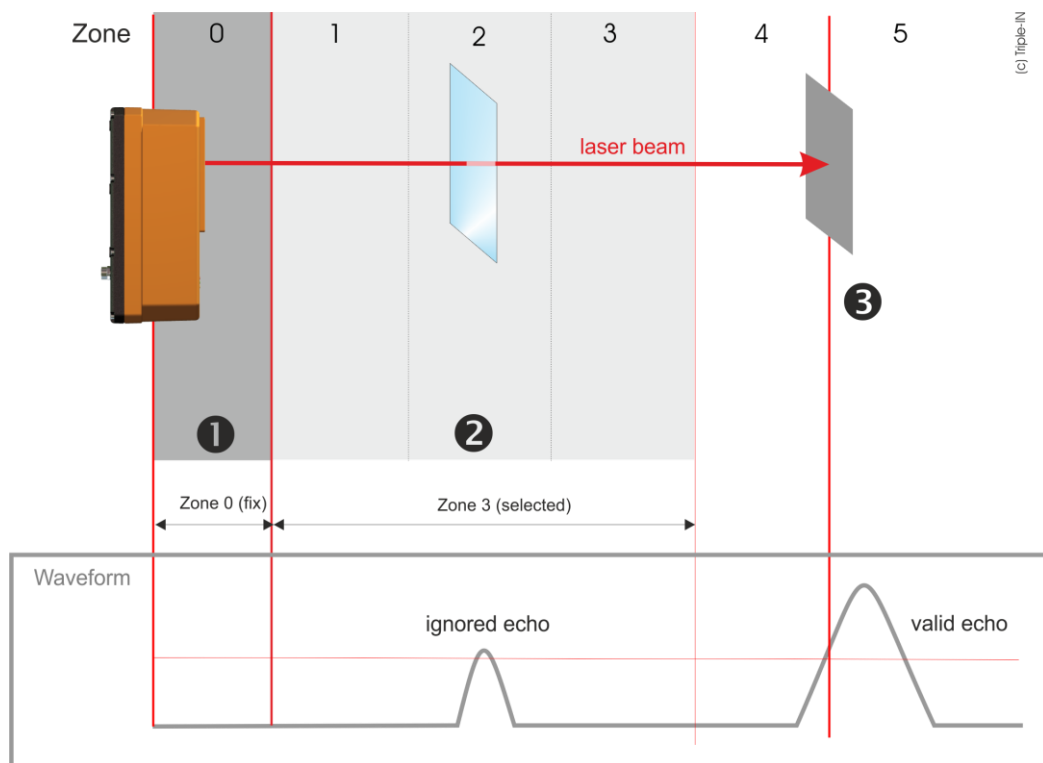

Figure 33: Near-field suppression: example with zone 3

8.6.2 Low echo filter

If the laser spot is only partly reflected by object edges, incorrect measurements may arise. A “low echo filter” removes measurements with echo signals less than 3%. To use

the full range of sensitivity, the low echo filter can be disabled. The user parameter must be set to 0.

The parameter is constant and cannot be changed. The PAC250-90-y-zz+ Laser Scanners have a predefined low echo filter setting.

Low echo filter; 0=disabled, 1=enabled

8.6.3 High echo filter

If the laser spot is reflected by several surfaces, incorrect measurements may arise due to deformations of the echo signal. The “high echo filter” removes measurements which appear with very wide echo signal amplitudes.

The high echo filter can be disabled to allow measurements on reflectors and reflecting foil. The user parameter must be set to 0.

The parameter is constant and cannot be changed. The PAC250-90-y-zz+ Laser Scanners have a predefined high echo filter setting.

High echo filter: 0=disabled, 1=enabled

8.7 Master echo selection

At measuring through rain, through protection windows, or in dusty surroundings several objects may reflect the laser beam.

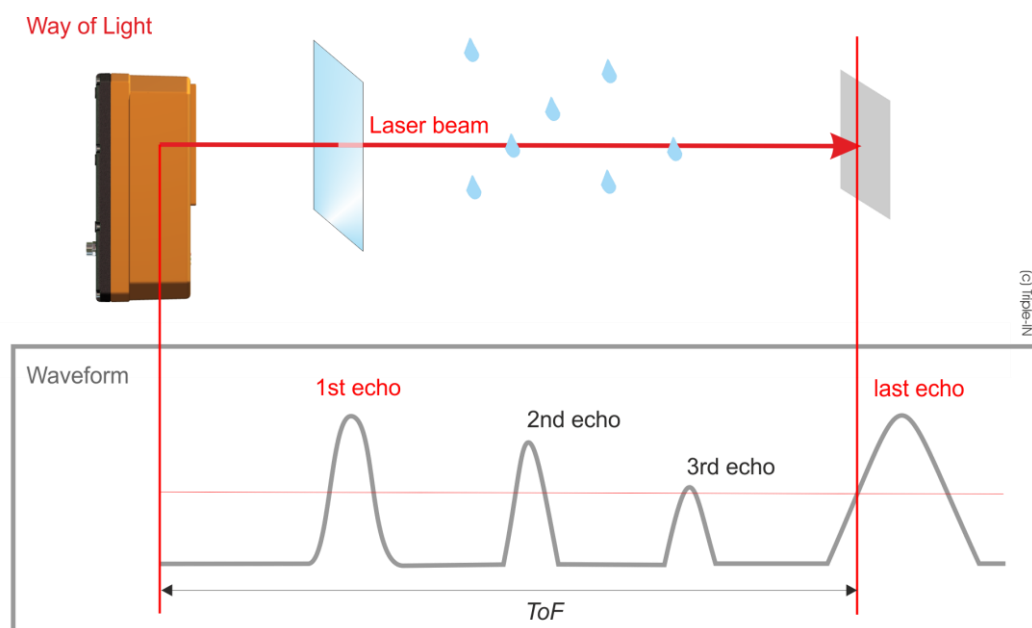

Figure 34: Multi echo with Master Echo selection

PAC250-90-y-zz+ Laser Scanners can process until 4 echoes but some of the data format can return only one or two. In those formats, the “Master Echo” identifies which echo of the 4 processed is returned.

The user parameter “Master echo” is used for configuration:

```
Master echo: 0=last, 1-4=echo index
```

- Scans contain the first echo (closest object) if the parameter has been set to “1”.
- Scans contain the second, third or fourth echo if the parameter is set respectively to “2”, “3” or “4”.
- If the parameter is set to “0”, the furthest measuring is returned.

8.8 Using Digital Outputs

8.8.1 Using the digital outputs as scan synchronization signal

One single digital output can be configured to provide a scan synchronization signal. The signal is set active with the first laser pulse, and it is set inactive with the last laser pulse of a scan.

The scan synchronization signal allows an accurate synchronization with other devices, such as GPS receivers and turn tables.

The scan synchronization signal is set active by setting the user parameter “Digital output function” to “1=sync”.

8.8.2 Setting the status of a digital output

The state of the digital switching outputs can be set by software. This allows a control computer to signal application depending status information to another system.

The feature is set active by setting the parameter “SW function” to “2=switch”.

The open/closed status of the output is set by the user parameter:

```
OUTn function: 2=switch  
OUTn status: 0=open, 1=closed
```

8.8.3 Using the digital outputs as pulser

User applications can set a counter value in advance to produce output signals of a specific count.

This function permits a control computer to transmit a counting stand or volume information as digital signals to another system. All digital switching outputs can be used

independently. The pulser feature is set active by setting the user parameter “SW function” to “3=pulser”.

The counter value must be written into the parameter:

```
Digital output pulser setup
```

The sensor firmware copies this value, sets the parameter register back to 0, and starts the count down. After this, new counts can be added to current output by writing another counter value. Make sure that the parameter “Digital output pulser setup” has reached 0 before adding new counts.

The hold time can be defined by the user parameter:

```
SW hold time [ms]
```

The delay between counter signals can be defined by the user parameter:

```
SW delay [ms]
```

The resolution of both timing parameters is about 10 ms.

Example

The following parameter setup:

```
53;          3; 1st Digital output function: 0=off, 1=sync, 2=switch,
3=pulser;
56;          10; 1st Digital output hold time [ms];
57;          20; 1st Digital output delay [ms];
58;          0; 1st Digital output logic: 0=normal, 1=low active;
59;          3; 2nd Digital output function: 0=off, 1=sync, 2=switch,
3=pulser;
62;          30; 2nd Digital output hold time [ms];
63;          40; 2nd Digital output delay [ms];
64;          1; 2nd Digital output logic: 0=normal, 1=low active;
```

In conjunction with the counter parameters:

```
55;          4; Temp: 1st Digital output: pulser setup;
61;          2; Temp: 2nd Digital output: pulser setup;
```

Results in the following signal pattern:

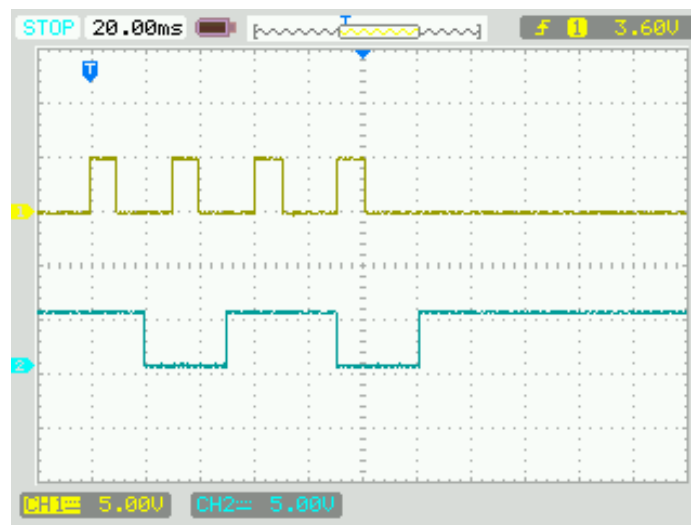

Figure 35: Digital output example signal pattern

8.9 Using digital inputs

8.9.1 Pulse per second PPS

A pulse per second (PPS) is an electrical signal that has a width of less than one second and a sharply rising or abruptly falling edge that accurately repeats once per second. PPS signals are typically provided by GPS receivers and are used for precise timekeeping and time measurement.

PAC250-90-y-zz+ Laser Scanners support the PPS signal in the following way:

- The internal sensor clock provides an internal counter on millisecond base.
- Each rising edge of the PPS signal increases a full second counter and resets the millisecond counter to 0.

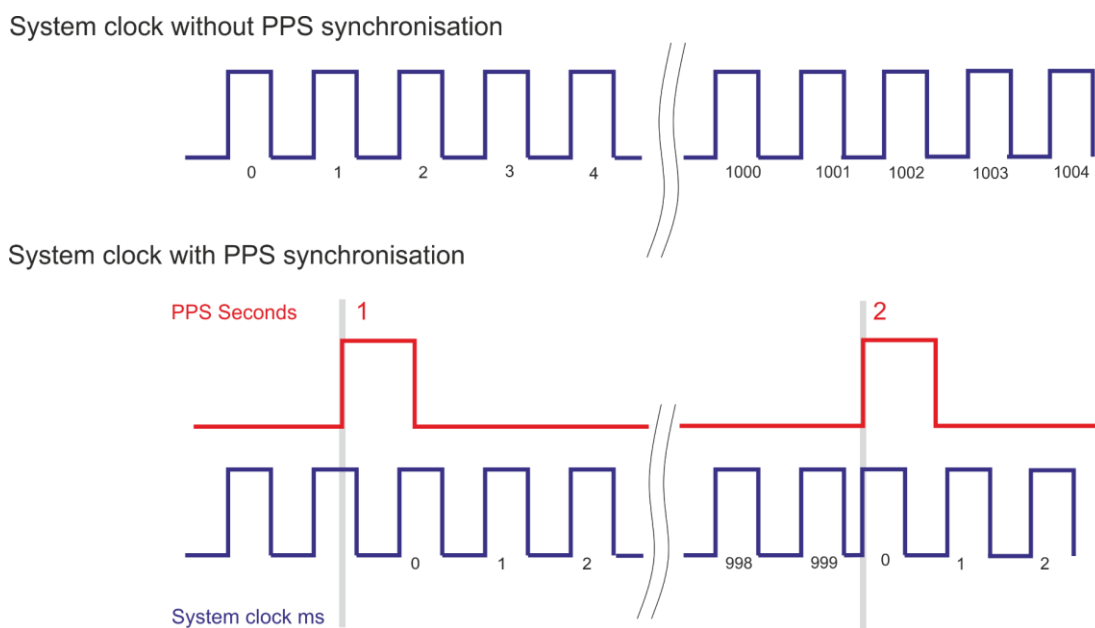

Figure 36: PPS signal

If the PPS signal occurs before a full sensor second, then the time stamps between PPS and sensor seconds are skipped.

If the PPS signal occurs after a full sensor second, time stamps may occur twice.

If the PPS input has been enabled, but no PPS source is connected, the internal clock continues to count milliseconds and provides the time stamp.

Only one single digital input can be used for the PPS signal. The sensor selects the first digital input defined.

The feature is set active by setting the parameter “IN function” to “2=PPS”:

Digital Input function: 1=enabled, 2=PPS, 3=RTC reset

The current number of PPS signals received can be obtained with the temporary user parameter “Digital input status”.

The command “SRTC Set real time clock counter” can be used to set the PPS counter to a specific second.

Example

The parameter “79 1st digital input function” has been set to “2=PPS” and a PPS input is connected.

The control computer has sent a SRTC command to set the real time clock counter to 3600000 milliseconds. The firmware used the value of 3600 seconds as new PPS signal counter.

The SRTC command is now 10 seconds ago and 10 PPS signals were received.

The user parameters will contain the following information:

```
79;          1; 1st Digital input function: 1=enabled, 2=PPS, 3=RTC
reset;
80;          3610; 1st Digital input status;
```

8.10 Controlling the heater

PAC250-90-y-zz+ Laser Scanners are equipped with an internal heater. Temperature parameters are handled in 1/10th degrees Celsius. Example: "321" are 32.1°C. The switching points of the heater can be configured by the user parameters

```
Air condition heater ON threshold [0.1 celsius]
Air condition heater OFF threshold [0.1 celsius]
```

The heater is switched on if the internal temperature is below the ON threshold and is switched off if the internal temperature is above the OFF threshold.

Note that the internal temperature during operation is about 15° Celsius above ambient temperature. Allow a hysteresis difference between the on and the off temperature of >5° Celsius.

The current heater status and the actual system temperature can be read from the user parameters

```
Temp: Air condition heater status, off=0, on=1
Const: Temperature sensor reading [0.1 celsius]
```

8.11 Reading the external Incremental Encoder

The PAC250-90-y-zz+ Laser Scanners provide one 3.3 to 5.0 Volt incremental encoder input. Purpose of the external incremental encoder is to report changes in the horizontal position of the sensor.

The incremental encoder must provide two pulses A and B. The PS Sensor firmware counts these pulses in both directions by use of one 32 bits register.

Input is limited to 128.000 counts/second.

The external incremental encoder must be enabled by setting the parameter

```
External incremental encoder: 0=disabled, 1=enabled=1;
```

An offset can be added to every encoder value:

```
External incremental encoder: offset;
```

The current reading plus offset can be read from parameter:

```
Temp: External incremental encoder: counts;
```

Reset of the counter is done at startup or with software by disabling and re-enabling the external incremental encoder.

9 Web interface

The PAC250-90-y-zz+ Laser Scanners provides a Web interface useful to check the sensor status and to make some configurations, like quick changes on user parameters.

9.1 Sensor information page

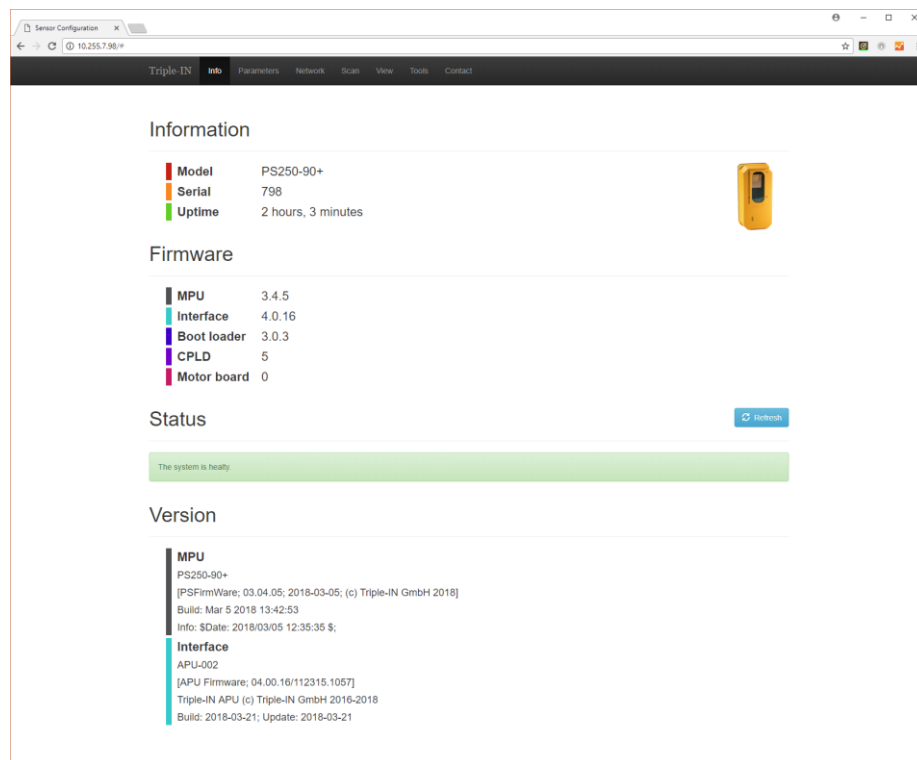

Figure 37: Web interface Info page

The Info page offers a glance on the sensor status and version. The four sections described below are available.

Information

Contains the sensor model, serial number and uptime (time since the previous power-up/restart of the APU).

Firmware

Shows the firmware version of the various sensor parts:

- MPU, Measurement Processing Unit
- APU, Application Processing Unit
- Boot loader (MPU boot loader)
- CPLD (Internal controlling circuit)
- Motor board (vertical deflection unit motor controller)

Status

In this section are shown all the issues the sensor can incur into. See Appendix A for more information.

Version

Shows detailed version information for the MPU and for the APU.

9.2 User parameters page

In this page, all the User Parameters are shown.

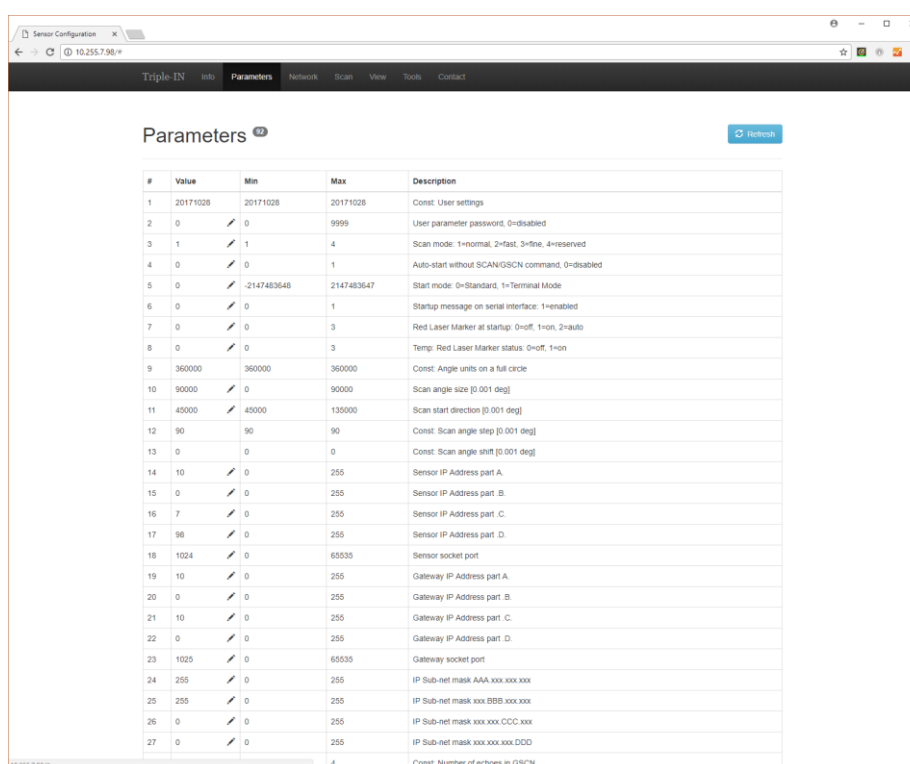

#	Value	Min	Max	Description
1	20171028	20171028	20171028	Const: User settings
2	0	0	9999	User parameter password, 0=disabled
3	1	1	4	Scan mode: 1=normal, 2=fast, 3=fine, 4=reserved
4	0	0	1	Auto-start without SCAN/GSCN command, 0=disabled
5	0	-2147483648	2147483647	Start mode: 0=Standard, 1=Terminal Mode
6	0	0	1	Startup message on serial interface, 1=enabled
7	0	0	3	Red Laser Marker at startup: 0=off, 1=on, 2=auto
8	0	0	3	Temp: Red Laser Marker status: 0=off, 1=on
9	360000	360000	360000	Const: Angle units on a full circle
10	90000	0	90000	Scan angle size [0.001 deg]
11	45000	45000	135000	Scan start direction [0.001 deg]
12	90	90	90	Const: Scan angle step [0.001 deg]
13	0	0	0	Const: Scan angle shift [0.001 deg]
14	10	0	255	Sensor IP Address part A.
15	0	0	255	Sensor IP Address part B.
16	7	0	255	Sensor IP Address part C.
17	98	0	255	Sensor IP Address part D.
18	1024	0	65535	Sensor socket port
19	10	0	255	Gateway IP Address part A.
20	0	0	255	Gateway IP Address part B.
21	10	0	255	Gateway IP Address part C.
22	0	0	255	Gateway IP Address part D.
23	1025	0	65535	Gateway socket port
24	255	0	255	IP Sub-net mask AAA.xxx.xxx.xxx
25	255	0	255	IP Sub-net mask xxx.BBB.xxx.xxx
26	0	0	255	IP Sub-net mask xxx.xxx.CCC.xxx
27	0	0	255	IP Sub-net mask xxx.xxx.xxx.DDD
			4	Const: Number of echoes in GSCN

Figure 38: Web interface Parameters page

The value of editable parameters can be modified just clicking on the pencil icon placed on the right of the value.

ID	Value	Icon	Value	Value	Description	
9	360000		360000	360000	Const. Angle units on a full circle	
10	<input type="text" value="90000"/>	<input checked="" type="checkbox"/>	<input type="checkbox"/>	0	90000	Scan angle size [0.001 deg]
11	45000	<input type="checkbox"/>	45000	135000	Scan start direction [0.001 deg]	
12	00		00	00	Const. Scan angle step [0.001 deg]	

Figure 39: Changing a parameter value on the Web interface

To confirm the modified value just click on the blue button on the right. Click on the gray button to keep the previous value.

9.3 Network page

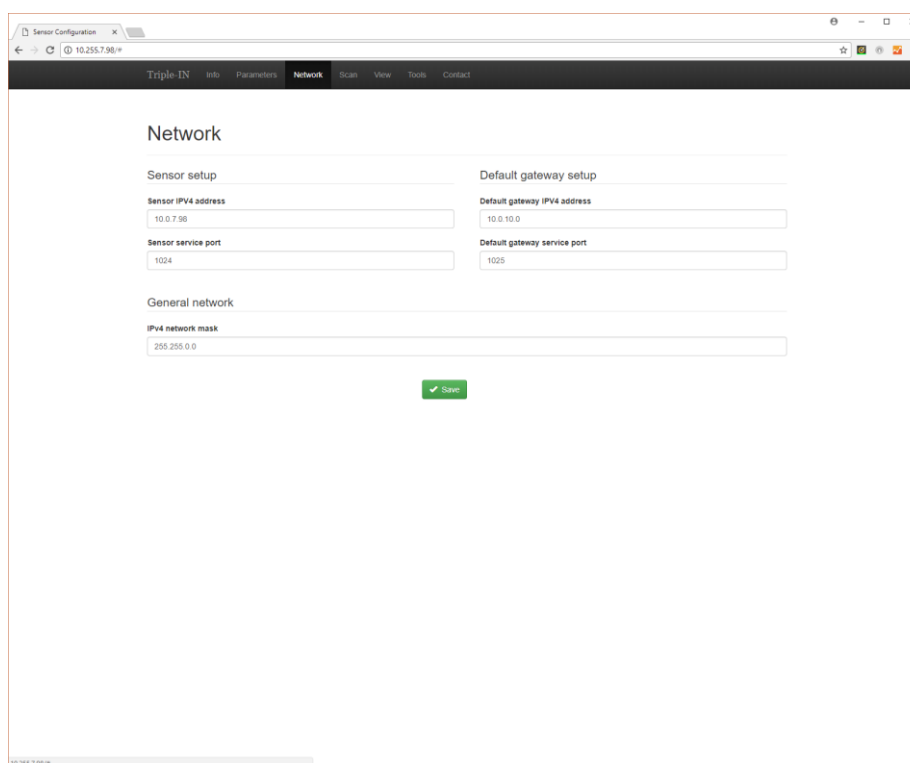

Figure 40: Web interface Network page

The Network page offers a simple way to modify the sensor network settings. Just modify the values as needed and press on the green **Save** button.

9.4 Scan page

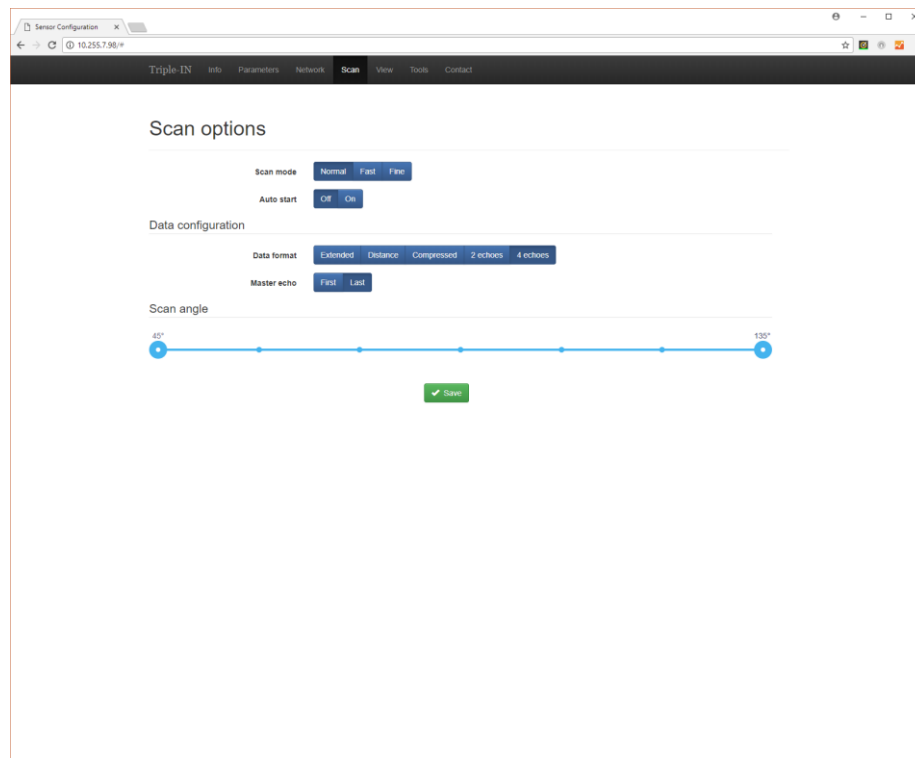

Figure 41: Web interface Scan page

In the Scan page, it is easy to modify in one shot the user parameters defining the returned scan lines.

- Scan mode
- Auto-start feature
- Data format
- Master echo
- Scan start direction
- Scan angle size

9.5 View page

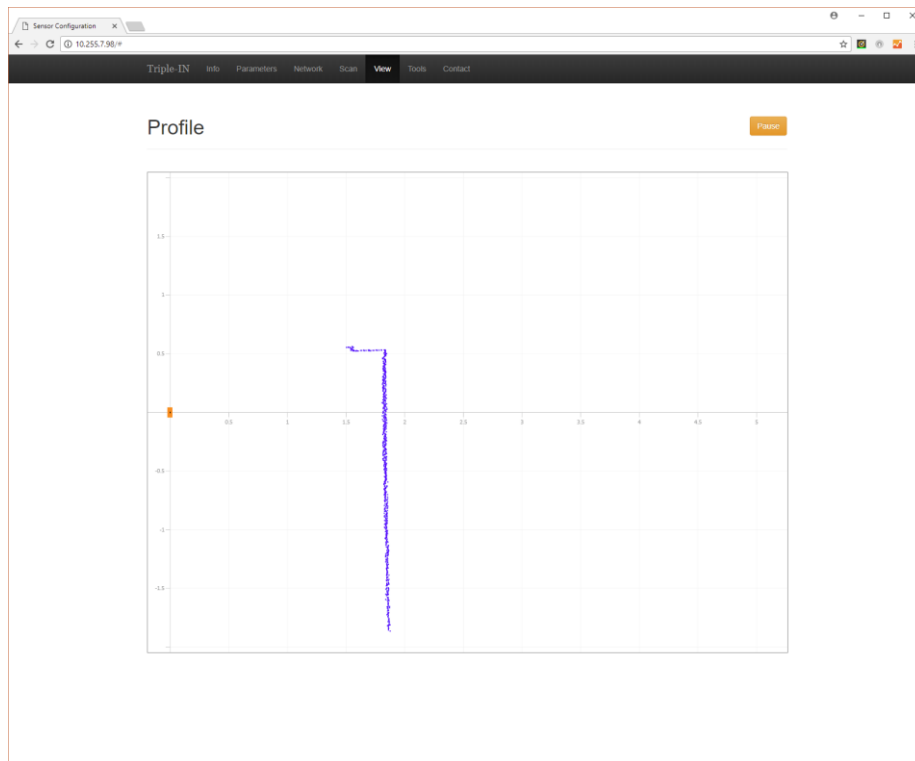

Figure 42: Web interface View page

The View page offers a preview of the scan line produced by the sensor.



Note

The display frequency in this page is sensibly lower than the real scan frequency. Delays between the acquisition time and display time can be in the order of few seconds.

9.6 Tools page

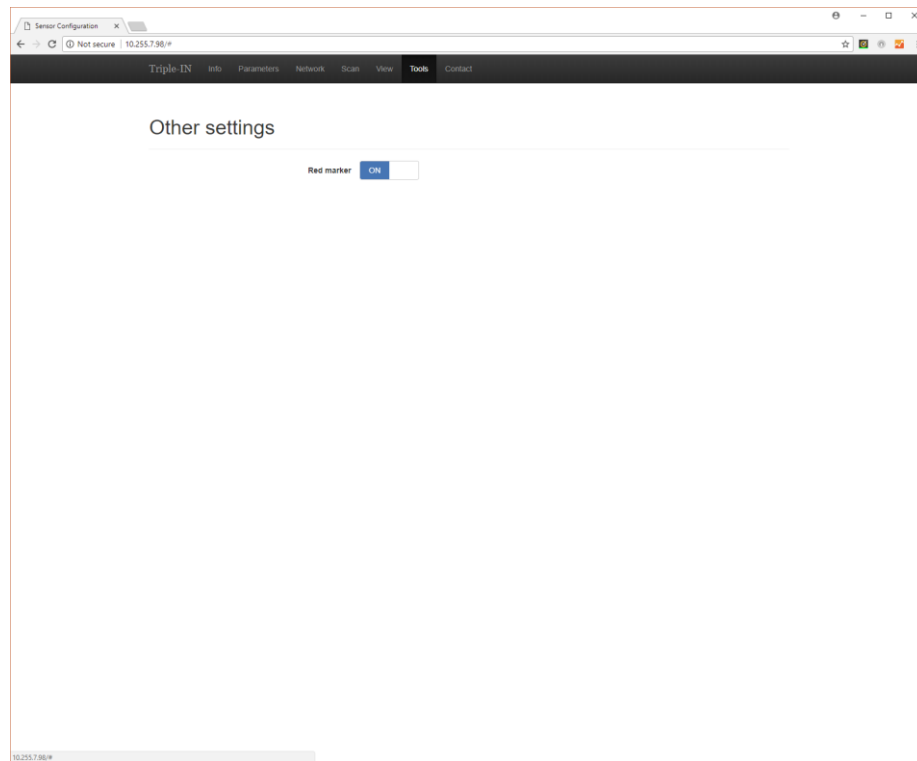

Figure 43: Web interface Tools page

This page offers the possibility to access to some special tools or settings.

9.7 Contacts page

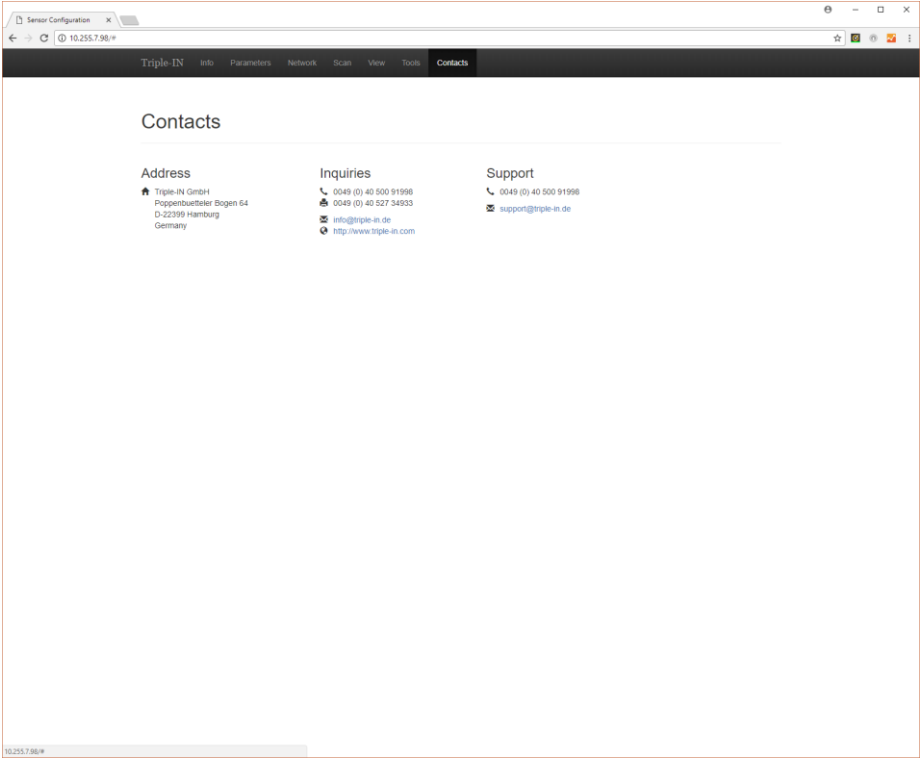

Figure 44: Web interface Contacts page

This page shows the various way to contact Triple-IN.

10 Firmware update

10.1 Updating MPU firmware

The MPU firmware of the PAC250-90-y-zz+ Laser Scanners can be updated over the serial interface by use of the XMODEM protocol. The sensor supports XMODEM-CRC and XMODEM-1K variants to improve performance and transfer safety.



Caution

Carefully read this entire instruction before you start updating your sensor.
Do not power off the sensor until the firmware is updated!

1. Download the new firmware image from Triple-IN's web server.
2. Make sure that the "MPU RS232" lines of the serial interface connector are connected to the serial interface of your computer.
3. Switch the sensor **on**.
4. Start TeraTerm. Wait until the following message has appeared on the terminal:

"Type 4 x ENTER to launch Terminal Mode"

5. Switch the sensor **off**.
6. Choose **File > Transfer > XModem > Send...**
7. Locate and single click on the required firmware binary file.
8. Select 1K from the options at the foot of the dialogue and click "Open"

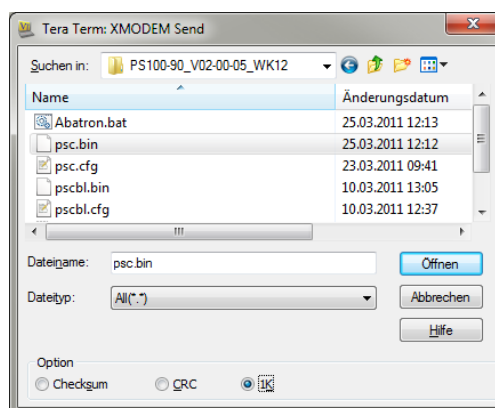

9. When the XMODEM Send dialogue is displayed in TeraTerm, power the sensor on
10. Data will start transferring to the sensor. TeraTerm will display progress:

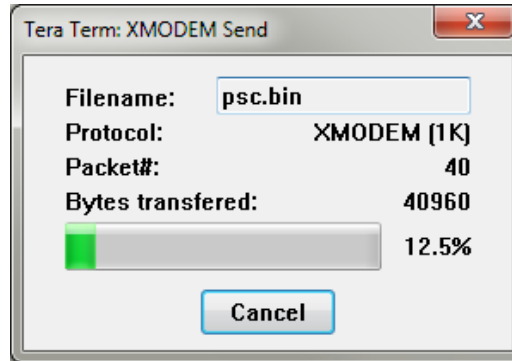

11. Once the firmware has been transferred, the sensor will update the firmware in the flash memory. This process needs about 30 seconds.

```
- new firmware; size: 328704  
- unlock and erase 20 blocks from 1 to 20  
- Programming from RAM 0x04001000 to ROM 0x00008000 = 164352 words
```

12. The sensor will now reboot the new firmware.

```
PS Laser Scanner  
[PS Firmware; 03.04.xx; 2018-01-20; (c) Triple-IN GmbH 2018]  
  
SN:          1234  
Local IP:    10.0.12.34:1024  
Gateway IP:  10.0.10.0:1025
```

For a clean restart, finally switch the sensor off and on again.

10.2 Updating APU firmware

The APU firmware of the PAC250-90-y-zz+ Laser Scanners can be performed using the Ethernet connection.

Download from the Triple-IN's web server the command line utility "TISendUpdate" and decompress the content of the archive. The folder directory will look like this:

```
02/06/2015 17:09      119 822 libgcc_s_dw2-1.dll  
02/06/2015 17:09      1 537 038 libstdc++-6.dll  
02/06/2015 17:09           80 384 libwinpthread-1.dll  
06/11/2017 14:07           456 README.txt  
06/11/2017 14:28      1 043 549 tisendupd.exe
```

The firmware upgrade is performed using a reserved TCP/IP connection on the port 3007. Using the tool “tisendupd.exe” the update is easy and safe. Just open a command prompt and write the command using this format:

```
tisendupd.exe -o UPDATE_FILE -a IPADDRESS[:PORT]
```

The PORT field can be omitted, and the default port will be used (3007).

```
C:\tisendupdate>tisendupd.exe -o 20180321.ttu -a 10.255.7.98
APU-002
[APU Firmware; 1.00/111B06.3315(rc2)]
Triple-IN Ethernet Updater (c) Triple-IN GmbH 2015-2017

- Connecting to: 10.255.7.98:3007 ...
  Connected!
- The device has accepted our request.
  > 256.0 KB transferred by now...
  > 512.0 KB transferred by now...
  > 768.0 KB transferred by now...
  > 1024.0 KB transferred by now...

...

  > 7.3 MB transferred by now...
  > 7.5 MB transferred by now...
  > 7.8 MB transferred by now...
  File completely sent. 7.9 MB transferred.
  The update process may take a while. Please wait...
- The device has received the update file.
- The device has checked the update file.
- The device is processing the update file.
  System is still updating. 4 minutes until timeout

...

  System is still updating. 4 minutes until timeout
- The update process is complete.
  The device is updated.
  Please restart it if needed!
```

As soon as the tool will finish its work, the APU will be restarted to complete the update.

11 Troubleshooting

11.1 LED indicators











The PAC250-90-y-zz+ Laser Scanners support 3 LEDs:

- Green LED: Power indicator; blinks if the scanner is in Terminal mode.
- Yellow LED: Measurement laser indicator.
- Red LED: Error indicator.

LEDs can be permanently turned off with the user parameter:

```
"Front side LEDs enabled=1, disabled=0."
```

The following table shows the meaning of the different combinations of the three LEDs.

Type	Name	Description
	Power off	
	Startup	all LEDs are on
	Self-test	All LEDs are blinking
	After self-test	System error has occurred, check system health status.
	Measurement laser off	Yellow is off
	Starting the motor, Waiting for SCAN command	Green is blinking Yellow is blinking
	scan in process	Green is steady on Yellow is steady on
	Terminal mode, waiting for user input	Green is blinking
	Terminal mode, Scan in process	Green is steady on Yellow is steady on
	System error	Red is steady on. Check system health status.

11.2 Self-test messages and System Health status

PAC250-90-y-zz+ Laser Scanners perform a self-test at startup and check various hardware components. All LEDs are blinking during the self-test.

The result of the self-test is reported on the RS232 of the MPU board.

```
PAC250-90-4
[PS Firmware; 03.xx.xx; 2017-01-20; (c) Triple-IN GmbH 2015]

SN:          1234
Local IP:    10.0.1.234 1024
Gateway IP: 10.0.10.0:1025

- Running self-test ...
- Warning [see below]
- Error [see below]
```

Figure 45: PS sensor start-up message with errors and warnings

The Terminal mode provides the function “2 - Show system health status”.

```
System health & Self-test bits;

-----
Bit ;      Result ; Error ;
-----
 0 ;      OK ; - Warning: Self-test not completed.
 1 ;      OK ; - Scan buffer is empty.
 2 ;      disabled ;
 3 ;      disabled ; - Error: Switching output failure!
 4 ;      disabled ; - Error: Digital input failure!
 5 ;      disabled ; - Error: External incremental encoder failure!
 6 ;      OK ; - Error: Check motor!
 7 ;      OK ; - Error: Check angle encoder and mirror
parameter!
 8 ;      disabled ; - Error: Front screen not clear!
 9 ;      OK ; - Error: Temperature out of operating range!
10 ;      OK ; - Warning: Check Ethernet!
11 ;      OK ; - Error: Check CPLD version.
12 ;      OK ; - Warning: Check serial number and model number
13 ;      OK ; - Warning: No basic system offset.
14 ;      OK ; - Warning: No basic system ppm.
15 ;      OK ; - Warning: No close range compensation.
16 ;      OK ; - Warning: No pulse width compensation.
17 ;      OK ; - Warning: No temperature drift compensation.
18 ;      OK ; - Warning: Check KEM-IC delay unit!
19 ;      OK ; - Error: Measurement clock error
20 ;      OK ; - Warning: Synthetic echoes are enabled!
21 ;      OK ; - Error: Cannot read Factory Parameter File!
22 ;      OK ; - Error: Cannot read compensation file!
23 ;      OK ; - Error: Cannot read User Parameter File!
28 ;      OK ; - Warning: Firmware update needs factory reset.
29 ;      OK ; - Error: Check communication board firmware!
30 ;      OK ; - Warning: System needs to restart.
```

Figure 46: System Health and Self-test bits in Terminal Mode

The following warnings can be fixed by the user:

- **Warning: User Parameter File was restored!**
The user parameter setup got lost, probably due to a power-off while parameters were written to the internal non-volatile memory.
Enter the terminal mode and check the user parameter setup.
- **Error: Temperature out of operating range!**
The sensor is too hot or too cold. Disconnect immediately from power supply and check the environmental conditions. Let the sensor operate only in its specified temperature range.

- **Warning: Check Ethernet!**
Check the Ethernet connections.
Restart the sensor to apply changed IP settings.
- **Warning: Firmware update needs factory reset.**
The firmware has been updated, but the parameter setup does not match for the new version. Restart the sensor. The sensor will ask for a parameter update.
- **Error: Check I/O Board version!**
The MPU firmware has been updated and requires a newer version of the communication board firmware.
- **Warning: System needs to restart.**
Restart the system by power-off and power-on.



Caution

Any other warning or error message reports a serious system defect. In this case, contact Triple-IN for a service and repair request.

Appendix

A System Status Bits

The System Status is a 32 bits word representing a bit mask. The following table describes the meaning of each bit when it is set to 1.

Bit	Type	Name	Description
0	Warning	System not ready	The system is performing a self-test. During this period are all other bits in this system status undefined
1	Info	Scan buffer is empty.	There are no scans in the buffer and a GSCN command will return no scan data
2	Info	Sensor operating in terminal mode.	Sensor operates in Terminal Mode and will not respond to commands
3	Error	Digital output failure!	A digital output detected a hardware failure
4	Error	Digital input failure!	A digital input detected a hardware failure
5	Error	External incremental encoder failure!	The external incremental encoder interface detected a hardware failure
6	Error	Check mirror motor!	The mirror motor is not running
7	Error	Check angle encoder settings!	Hardware configuration problem. Please contact service
8	Error	Check field of view!	Clean the front window
9	Error	Temperature out of operating range!	The temperature is outside of the operating range of the sensor
10	Warning	Check Ethernet	There is no Ethernet connection
11	Error	Check CPLD version!	Hardware configuration problem. Please contact service
12	Warning	Check serial number and sensor model number	Hardware configuration problem. Please contact service
13	Warning	No basic system offset	Hardware configuration problem. Please contact service
14	Warning	No basic system ppm	Hardware configuration problem. Please contact service
15	Warning	No close-range compensation	Hardware configuration problem. Please contact service
16	Warning	No pulse width compensation	Hardware configuration problem. Please contact service
17	Warning	No temperature drift compensation	Hardware configuration problem. Please contact service
18	Warning	Check KEM-IC delay unit	Hardware configuration problem. Please contact service
19	Error	Measurement clock error!	Hardware failure. Please contact service
20	Warning	Synthetic echoes are enabled	Hardware configuration problem. Please contact service
21	Error	Cannot read Factory Parameter file!	Hardware configuration problem. Please contact service
22	Error	Cannot read compensation file!	Hardware configuration problem. Please contact service
23	Error	Cannot read User Parameter file!	Hardware configuration problem. Please contact service
24	Warning	Check mirror/scan line settings	Hardware configuration problem. Please contact service
25	Info	Measurement laser is switched off.	The measurement laser has been disabled by the user
26	Warning	User configuration disabled	Hardware configuration problem. Please contact service
27		Reserved for future use	
28	Warning	Firmware update needs factory reset	Restart the sensor
29	Error	Check communication board version!	Update the communication board firmware to the latest version
30	Warning	System needs to restart	Restart the sensor
31		Reserved for future use	

B Technical Specification

Ordering information

Model	Article number
PAC250-90-4-18+	SR-C9XX-144C-P0
PAC250-90-y-zz +	On request

Technical Data

Sensor	PAC250-90 -4-18+	PAC250-90 -y-zz+
Article variation	C	<i>On request</i>
WORKING RANGE		
Maximum Range @ R = 100%, Lambertian Reflector (m)		250
Maximum Range @ R = 10%, Lambertian Reflector (m)		80
Minimum Range (m)		1.6
ACCURACY DATA		
Resolution (mm)		1
Repeatability 1 σ @ strong signal (mm)		5
Repeatability 1 σ @ weak signal (mm)		20
Accuracy (systematic error) (mm)		≤ 5
SPOT PROPERTIES		
Divergence in scan direction (°)		0.076
Divergence in scan direction (mrad)		1.33
Divergence perpendicular to scan direction (°)		0.029
Divergence perpendicular to scan direction (mrad)		0.5
Spot close to the sensor window (mm)		12 x 18
Standard focus distance (m)		45
SCAN PROPERTIES		
Maximum Scan and Profile Angle		90°
Angle between outer scan planes (°) <i>Measured at middle of scan angular plane, no tilting</i>	18	1.5 x N
Angle between inner scan planes (°) <i>Measured at middle of scan angular plane, no tilting</i>	6	0.5 x N
Scan lines	4	2, 3 or 4
Scan Mirror Type	4 Mirror Polygon	

Maximum Scanning Duty Cycle	50%
OPERATIONAL MODES	
Normal Mode	
Beam Scan Angle Step (°)	0.09
Measurements in 90° Scan	1000
Scan Rate (Hz)	30
Scan Time @ 90° Scan (ms)	16.65
Gap between Spots in Scan (°)	0.014
Fine Mode	
Beam Scan Angle Steps in Profile (°)	0.0225
Measurements in 90° Scan	1000
Scan Rate (Hz)	30
Scan Time @ 90° Scan (ms)	16.65
Scans/Profile (interlace)	4
Profile Rate (Hz)	7.5
Profile Time @ 90° Scan (ms)	134
Measurements in Profile (4 scans interlace)	4000
Overlap of Spots in Scan (°)	0.0535
Fast Mode	
Beam Scan Angle Step (°)	0.18
Measurements in 90° Scan	500
Scan Rate (Hz)	60
Scan Time @ 90° Scan (ms)	8.5
Gap between Spots in Scan (°)	0.104
MULTI-ECHO EVALUATION	
Echoes evaluated	Up to 4
Selectable echoes	From 1st to 4th or last echo
TARGET SURFACE TEMPERATURE	
Surface Temperature Range	T < 500°C
LASER DATA	
Measurement Laser	
Measurement Laser Type	Pulse Laser Diode
Wave Length (nm)	905
Safety Class; EN 60825-1; 94,96,01	1
Measurement or Pulse Rate (kHz)	Up to 60 kHz
Red Laser Marker	
Red Laser Marker (indicate the spot)	DC Laser Diode
Wave Length (nm)	635-678
Safety Class; EN 60825-1; 94,96,01	2
INTERFACES	
Ethernet	TCP and UDP 100 Mb/s
RS232 for Sensor Programming	115 kBaud, 8n1
Digital Outputs	2 x 3.3 to 5 VDC programmable isolated switching outputs
Digital Inputs	2 x 3.3 to 5 VDC programmable isolated inputs
External encoder	3.3 to 5 volts TTL input, channels A and B
POWER SUPPLY	
Power Voltage	24 VDC ± 5 VDC power supply, 3.3 to 5 VDC for I/O

Triple-IN

Direct Power Supply	yes
PoE Power Supply	yes
Power Consumption (W)	8 (33 with heater on)
Start-up Time (s)	< 30
SENSOR PROTECTION	
Ingress Protection	IP67
Operating Temperature Range	-30°C to +50°C
Temperature Range for Storage	-30°C to + 70°C
Enclosure	Aluminium, Die Cast; Seawater resistant
Enclosure Finish	Powder coated
Front Screen	AR-coated glass
Function in strong Sunshine	Ambient light control
DIMENSIONS & WEIGHT	
Height x Width x Length (mm)	247 x 121 x 109
Weight (kg)	2.8

Dimensional drawings and outlines

❖ Note

The following drawings are without scale.

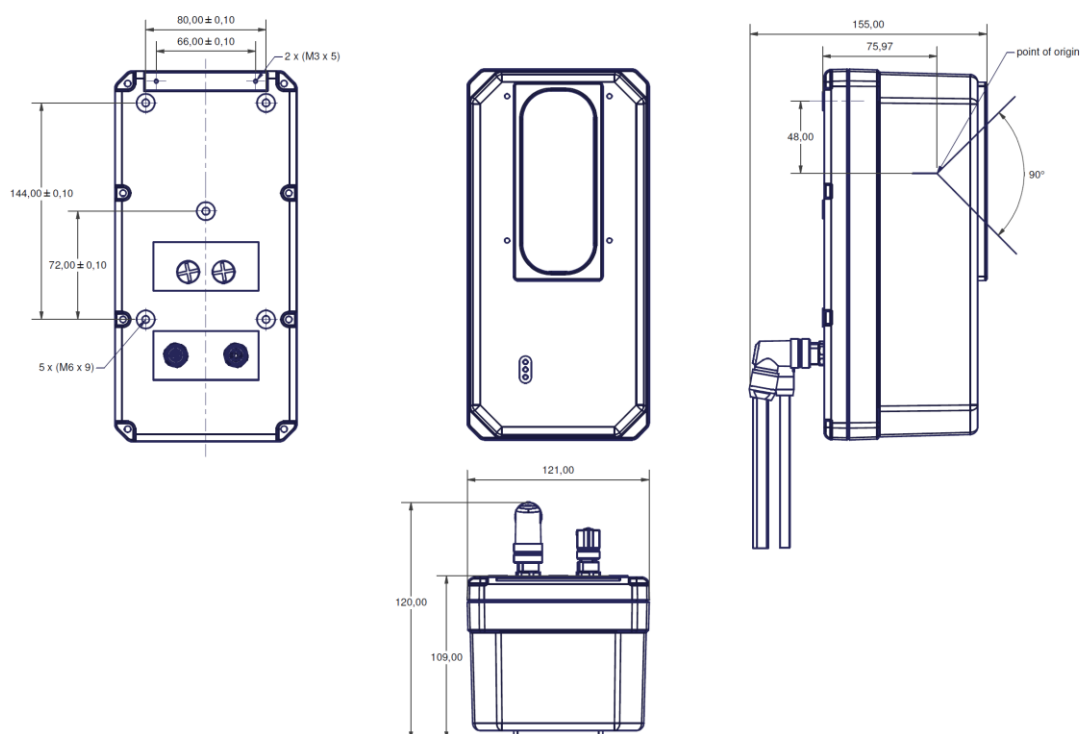

Figure 47: PAC250-90-y-zz+ Laser Scanners outlines (no scale)

Multifunction cable layout

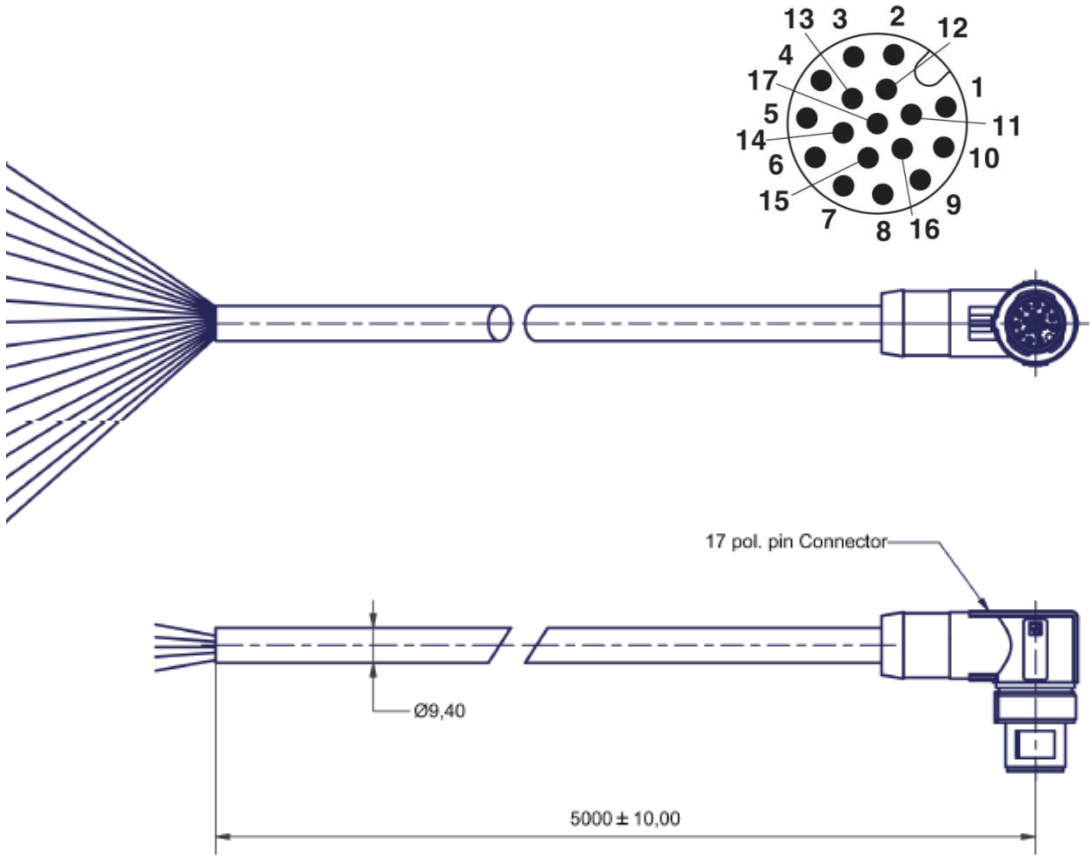

Figure 48: Multifunction cable

Ethernet and PoE cable layout

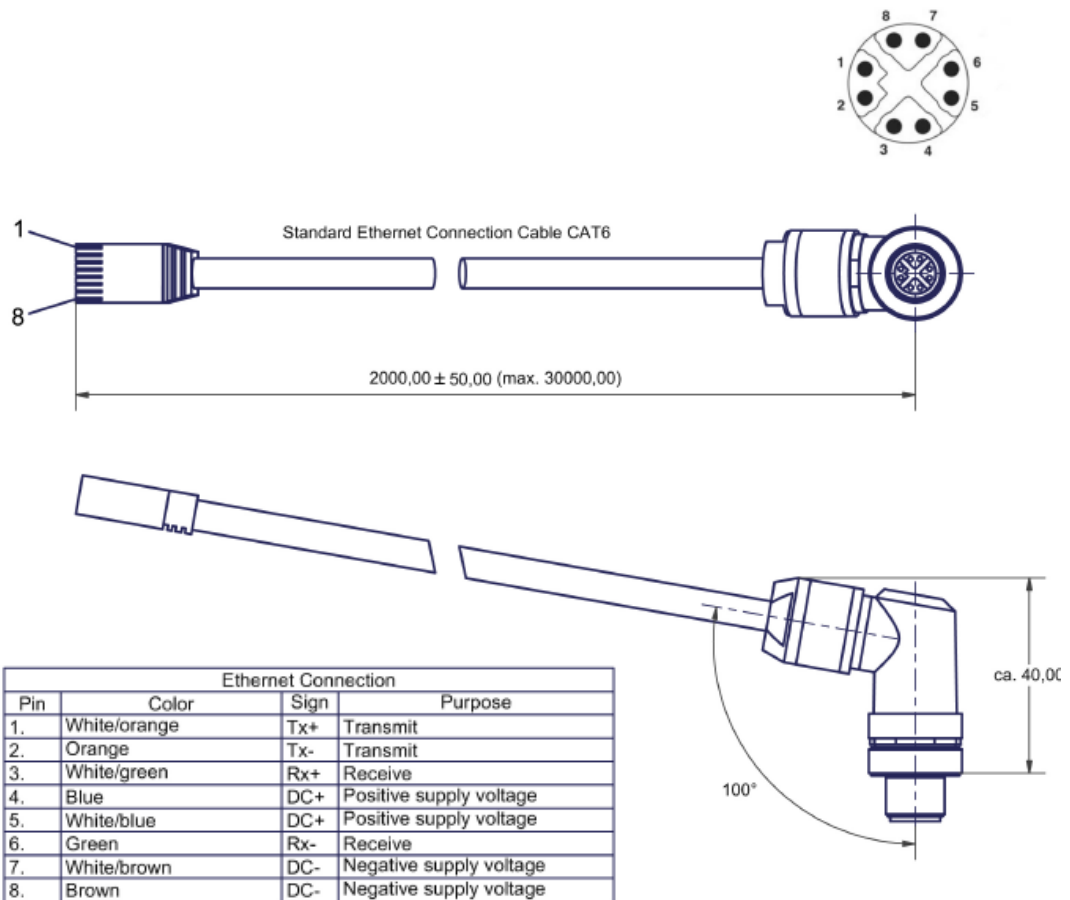

Figure 49: Ethernet and PoE cable

3D CAD Model

A 3D CAD model (STEP format) of the PAC250-90-y-zz+ Laser Scanners outlines is available on demand.